



## Oil and Gas Products

### Pressures to 30,000 psi

**MAXIMATOR** has been designing and manufacturing specialty products to the high pressure market for over thirty years and has a worldwide reputation for quality and reliability.

#### Oil and Gas Products feature:

- ▶ Annealed 316 stainless steel construction meets NACE MR0175.
- ▶ Rising stem designs, both solid and 2 piece configuration available.
- ▶ Metal-to-metal seating achieves bubble-tight shut-off.
- ▶ Carbon-reinforced PTFE with metal back-up rings offers reliable stem to body sealing.
- ▶ Stem sleeve and packing gland materials have been selected to achieve the optimum corrosion resistance to withstand offshore environments.
- ▶ Safety weep holes for all pressure connections and packing area.
- ▶ Seven different valve body patterns, with choice of vee or regulating type stem tip.

HPT offers a diverse line of high pressure equipment for all your Oil and Gas applications. Not all options can be applied to the standard valve series, see specific product pages for ordering options.

**Note:** When selecting multiple items, the pressure rating would be that of the lowest rated component.

#### Oil and Gas Products Index

Valves rated to 22,500 psi . . . . .	2 - 3
Valves rated to 30,000 psi . . . . .	4 - 5
Gauge & Bleed Valves. . . . .	6 - 7
Fittings . . . . .	8
Tubing and Threaded Nipples . . . . .	9
Check Valves . . . . .	10
Line Filters . . . . .	11
Adapters & Couplings . . . . .	12 - 13



# Sour Gas Valves

## Pressures to 22,500 psi

**MAXIMATOR** Sour Gas valves are designed for oil and gas service where H<sub>2</sub>S is present. All valve bodies are made from annealed 316 stainless steel, with K-Monel stems in compliance with NACE MRO175. These needle valves with metal to metal seats have a high level of safety and reliability under harsh operating conditions. These valves may be used both with gases and liquids.

Traceability is ensured through extensively documented data (batch number, maximum pressure, material number, type designation). All Sour Gas components are supplied with glands and collars unless otherwise specified.

O.D. Size (in.)	Connection Type	Orifice Size (in.)	Rated Cv*	Pressure/Temp. Rating (psi @ R.T.)* *
1/4	4HF	0.094	0.12	22,500
3/8	6HF	0.125	0.23	22,500
9/16	9HF	0.125	0.33	22,500

\* Cv values shown are for 2-way straight pattern vee stem valves. For 2-way angle patterns, increase the Cv value by 50%.

\*\* See page 2 in the Technical Section for Pressure/Temperature Rating Chart.

### Ordering Information

Typical catalog number: **22V4H001-SOG**

22V	4H	00	1	-SOG	
Valve Series	O.D. Tube Size	Stem Type	Body Pattern	Connection Options	Temperature options*
22V	4H - 1/4" 6H - 3/8" 9H - 9/16"	00 - one piece rotating Vee stem 01 - one piece rotating Regulating stem 07 - non-rotating Vee stem 08 - non-rotating Regulating stem 80 - one piece Vee stem with replaceable seat 81 - one piece Regulating stem with replaceable seat 87 - non-rotating Vee stem with replaceable seat 88 - non-rotating Regulating stem with replaceable seat	1 - two-way straight 2 - two-way angle 3 - three-way, two on pressure 4 - three-way, one on pressure 5 - three-way, two-stem manifold	SOG - Sour Gas Service with annealed collars and glands  SOGWO - Sour Gas Service without collars and glands	No option chosen is standard Teflon/Carbon packing rated to 450 °F  TG - Teflon glass packing rated to 600 °F  GY - Graphite braided yarn packing rated to 800 °F

**Flow Coefficient Reference Curves (Cv)**

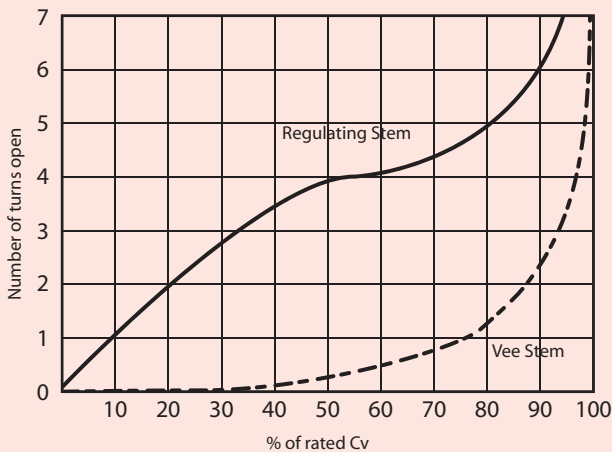

### Repair Kits

Consult your HPT representative for repair kits and valve bodies. Refer to the Tools and Installation section for proper maintenance procedures.

All general terms and conditions of sale, including limitations of our liability, apply to all products and services sold.  
MT R1 0311

# Sour Gas Valves

## Pressures to 22,500 psi

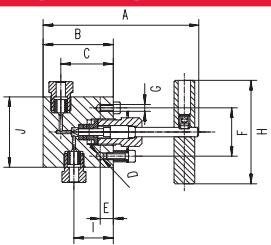
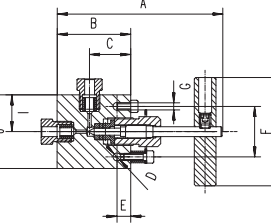
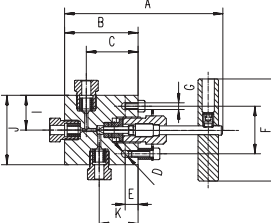
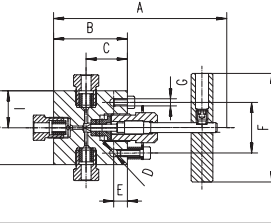
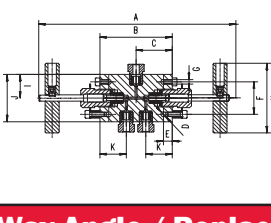
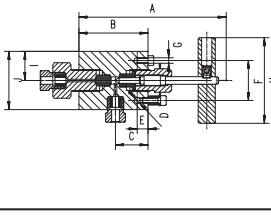
Valve Pattern	Catalog Number	Stem Type	O.D. Tube (in.)	Orifice (in.)	Dimensions (in.)										Valve Panel Hole	Block Thickness
					A	B	C	D	E	F	H	I	J	K		
<b>2-Way Straight</b>																
	22V4H001-SOG	Vee	1/4	0.094	4.96	2.01	1.50	0.22	0.37	1.38	2.95	1.12	2.01		1.00	1.02
	22V4H011-SOG	Reg														
	22V6H001-SOG	Vee	3/8	0.125	4.96	2.01	1.50	0.22	0.37	1.38	2.95	1.12	2.01		1.00	1.02
	22V6H011-SOG	Reg														
	22V9H001-SOG	Vee	9/16	0.125	5.00	2.44	1.56	0.22	0.37	1.38	2.95	1.12	2.64		1.00	1.54
	22V9H011-SOG	Reg														
<b>2-Way Angle</b>																
	22V4H002-SOG	Vee	1/4	0.094	4.96	2.01	1.12	0.22	0.37	1.38	2.95	1.00	2.01		1.00	1.02
	22V4H012-SOG	Reg														
	22V6H002-SOG	Vee	3/8	0.125	4.78	2.20	1.10	0.22	0.37	1.38	2.95	1.00	2.01		1.00	1.02
	22V6H012-SOG	Reg														
	22V9H002-SOG	Vee	9/16	0.125	5.00	2.44	1.12	0.22	0.37	1.38	2.95	1.32	2.64		1.00	1.54
	22V9H012-SOG	Reg														
<b>3-Way / 2 on Pressure</b>																
	22V4H003-SOG	Vee	1/4	0.094	4.69	2.13	1.50	0.22	0.37	1.38	2.95	1.00	2.01	1.12	1.00	1.02
	22V4H013-SOG	Reg														
	22V6H003-SOG	Vee	3/8	0.125	5.08	2.50	1.50	0.22	0.37	1.38	2.95	1.00	2.01	1.12	1.00	1.02
	22V6H013-SOG	Reg														
	22V9H003-SOG	Vee	9/16	0.125	5.45	2.87	1.56	0.22	0.37	1.38	2.95	1.32	2.64	1.12	1.00	1.54
	22V9H013-SOG	Reg														
<b>3-Way / 1 on Pressure</b>																
	22V4H004-SOG	Vee	1/4	0.094	4.96	2.01	1.12	0.22	0.37	1.38	2.95	1.00	2.01		1.00	1.02
	22V4H014-SOG	Reg														
	22V6H004-SOG	Vee	3/8	0.125	4.76	2.20	1.12	0.22	0.37	1.38	2.95	1.00	2.01		1.00	1.02
	22V6H014-SOG	Reg														
	22V9H004-SOG	Vee	9/16	0.125	5.00	2.44	1.12	0.22	0.37	1.38	2.95	1.32	2.64		1.00	1.54
	22V9H014-SOG	Reg														
<b>3-Way / 2-Stem Manifold</b>																
	22V4H005-SOG	Vee	1/4	0.094	8.23	3.07	1.54	0.22	0.37	1.38	2.95	1.00	2.01	1.12	1.00	1.02
	22V4H015-SOG	Reg														
	22V6H005-SOG	Vee	3/8	0.125	8.39	3.25	1.61	0.22	0.37	1.38	2.95	1.00	2.01	1.12	1.00	1.02
	22V6H015-SOG	Reg														
	22V9H005-SOG	Vee	9/16	0.125	8.90	3.74	1.88	0.22	0.37	1.38	2.95	1.32	2.64	1.12	1.00	1.54
	22V9H015-SOG	Reg														
<b>2-Way Angle / Replaceable Seat</b>																
	22V4H802-SOG	Vee	1/4	0.094	4.96	2.38	1.12	0.22	0.37	1.38	2.95	1.00	2.01	0.90	1.00	1.02
	22V4H812-SOG	Reg														
	22V6H802-SOG	Vee	3/8	0.125	4.96	2.38	1.12	0.22	0.37	1.38	2.95	1.00	2.01	1.15	1.00	1.02
	22V6H812-SOG	Reg														
	22V9H802-SOG	Vee	9/16	0.125	5.00	2.44	1.18	0.22	0.37	1.38	2.95	1.32	2.64	1.48	1.00	1.54
	22V9H812-SOG	Reg														

G - Panel mounting screw thread size 10-24 UNC.

All dimensions are for reference only and are subject to change.

All SOG components are furnished with collars and glands, to receive without, add the suffix "WO" to the catalog number, "22V6H002-SOG-WO."

# Sour Gas Valves

Pressures to 30,000 psi

**MAXIMATOR** Sour Gas valves are designed for oil and gas service where H<sub>2</sub>S is present. All valve bodies are made from annealed 316 stainless steel, with K-Monel stems in compliance with NACE MRO175. These needle valves with metal to metal seats have a high level of safety and reliability under harsh operating conditions. These valves may be used both with gases and liquids.

Traceability is ensured through extensively documented data (batch number, maximum pressure, material number, type designation). All Sour Gas components are supplied with glands and collars unless otherwise specified.

O.D. Size (in.)	Connection Type	Orifice Size (in.)	Rated Cv*	Pressure/Temp. Rating (psi @ R.T.)* *
1/4	4HF	0.062	0.08	30,000
3/8	6HF	0.062	0.09	30,000
9/16	9HF	0.078	0.14	30,000

\* Cv values shown are for 2-way straight pattern vee stem valves. For 2-way angle patterns, increase the Cv value by 50%.

\*\* See page 2 in the Technical Section for Pressure/Temperature Rating Chart.

## Ordering Information

Typical catalog number: **30V4H001-SOG**

30V	4H	00	1	-SOG	
Valve Series	O.D. Tube Size	Stem Type	Body Pattern	Connection Options	Temperature options
30V	4H - 1/4" 6H - 3/8" 9H - 9/16"	00 - one piece rotating Vee stem 01 - one piece rotating Regulating stem 07 - non-rotating Vee stem 08 - non-rotating Regulating stem 80 - one piece Vee stem with replaceable seat 81 - one piece Regulating stem with replaceable seat 87 - non-rotating Vee stem with replaceable seat 88 - non-rotating Regulating stem with replaceable seat	1 - two-way straight 2 - two-way angle 3 - three-way, two on pressure 4 - three-way, one on pressure 5 - three-way, two-stem manifold	SOG - Sour Gas Service with annealed collars and glands  SOGWO - Sour Gas Service without collars and glands	No option chosen is standard Teflon/Carbon packing rated to 450° F  TG - Teflon glass packing rated to 600° F  GY - Graphite braided yarn packing rated to 800° F

**Flow Coefficient Reference Curves (Cv)**

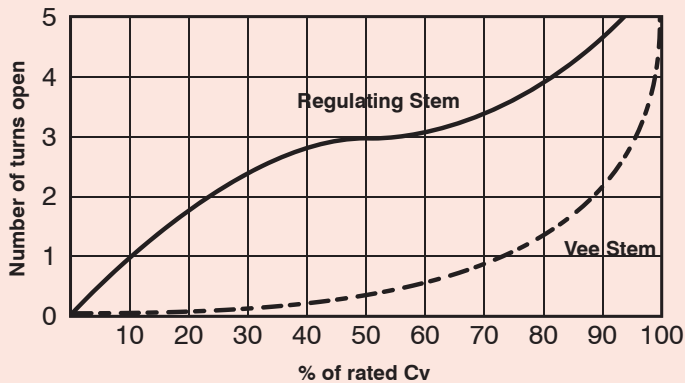

## Repair Kits

Consult your **HPT** representative for repair kits and valve bodies. Refer to the Tools and Installation section for proper maintenance procedures.

All general terms and conditions of sale, including limitations of our liability, apply to all products and services sold.  
MT R1 0311

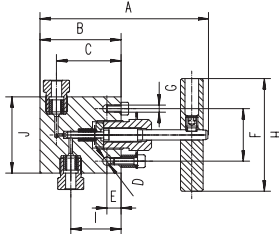
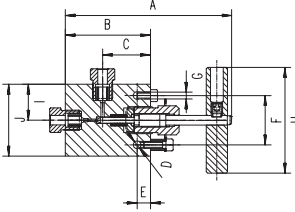
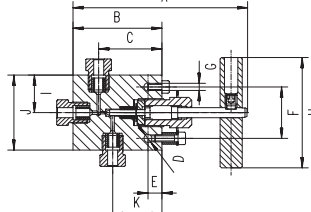
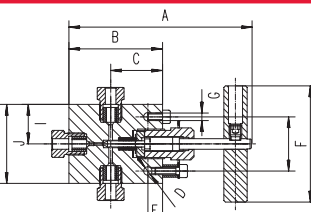
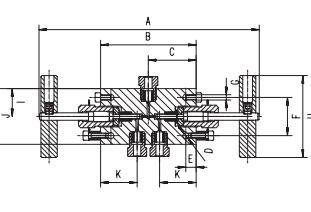
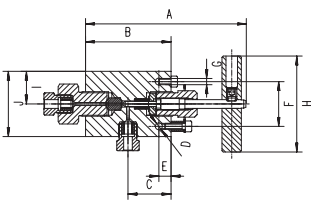
Valve Pattern	Catalog Number	Stem Type	O.D. Tube (in.)	Orifice (in.)	Dimensions (in.)										Valve Panel Hole	Block Thickness
					A	B	C	D	E	F	H	I	J	K		
<b>2-Way Straight</b>																
	30V4H001-SOG	Vee	1/4	0.062	4.67	2.13	1.69	0.22	0.37	1.38	2.95	1.32	2.01		1.00	1.02
	30V4H011-SOG	Reg														
	30V6H001-SOG	Vee	3/8	0.062	4.80	2.24	1.69	0.22	0.37	1.38	2.95	1.32	2.01		1.00	1.02
	30V6H011-SOG	Reg														
	30V9H001-SOG	Vee	9/16	0.078	5.04	2.50	1.75	0.22	0.37	1.38	2.95	1.30	2.64		1.00	1.54
	30V9H011-SOG	Reg														
<b>2-Way Angle</b>																
	30V4H002-SOG	Vee	1/4	0.062	4.96	2.38	1.34	0.22	0.37	1.38	2.95	1.00	2.01		1.00	1.02
	30V4H012-SOG	Reg														
	30V6H002-SOG	Vee	3/8	0.062	5.16	2.62	1.32	0.22	0.37	1.38	2.95	1.00	2.01		1.00	1.02
	30V6H012-SOG	Reg														
	30V9H002-SOG	Vee	9/16	0.078	5.35	2.80	1.32	0.22	0.37	1.38	2.95	1.32	2.64		1.00	1.54
	30V9H012-SOG	Reg														
<b>3-Way / 2 on Pressure</b>																
	30V4H003-SOG	Vee	1/4	0.062	4.96	2.38	1.69	0.22	0.37	1.38	2.95	1.00	2.01	1.32	1.00	1.02
	30V4H013-SOG	Reg														
	30V6H003-SOG	Vee	3/8	0.062	5.31	2.76	1.69	0.22	0.37	1.38	2.95	1.00	2.01	1.32	1.00	1.02
	30V6H013-SOG	Reg														
	30V9H003-SOG	Vee	9/16	0.078	5.71	3.15	1.75	0.22	0.37	1.38	2.95	1.32	2.64	1.30	1.00	1.54
	30V9H013-SOG	Reg														
<b>3-Way / 1 on Pressure</b>																
	30V4H004-SOG	Vee	1/4	0.062	4.96	2.38	1.32	0.22	0.37	1.38	2.95	1.00	2.01		1.00	1.02
	30V4H014-SOG	Reg														
	30V6H004-SOG	Vee	3/8	0.062	5.16	2.62	1.32	0.22	0.37	1.38	2.95	1.00	2.01		1.00	1.02
	30V6H014-SOG	Reg														
	30V9H004-SOG	Vee	9/16	0.078	5.35	2.80	1.32	0.22	0.37	1.38	2.95	1.32	2.64		1.00	1.54
	30V9H014-SOG	Reg														
<b>3-Way / 2-Stem Manifold</b>																
	30V4H005-SOG	Vee	1/4	0.062	8.56	3.44	1.72	0.22	0.37	1.38	2.95	1.00	2.01	1.32	1.00	1.02
	30V4H015-SOG	Reg														
	30V6H005-SOG	Vee	3/8	0.062	8.86	3.76	1.89	0.22	0.37	1.38	2.95	1.00	2.01	1.32	1.00	1.02
	30V6H015-SOG	Reg														
	30V9H005-SOG	Vee	9/16	0.078	9.25	4.13	2.07	0.22	0.37	1.38	2.95	1.32	2.64	1.30	1.00	1.54
	30V9H015-SOG	Reg														
<b>2-Way Angle / Replaceable Seat</b>																
	30V4H802-SOG	Vee	1/4	0.062	5.16	2.62	1.32	0.22	0.37	1.38	2.95	1.00	2.01	0.83	1.00	1.02
	30V4H812-SOG	Reg														
	30V6H802-SOG	Vee	3/8	0.062	5.16	2.62	1.32	0.22	0.37	1.38	2.95	1.00	2.01	1.07	1.00	1.02
	30V6H812-SOG	Reg														
	30V9H802-SOG	Vee	9/16	0.078	5.16	2.62	1.32	0.22	0.37	1.38	2.95	1.32	2.64	1.47	1.00	1.54
	30V9H812-SOG	Reg														

G - Panel mounting screw thread size 10-24 UNC.

All dimensions are for reference only and are subject to change.

All SOG components are furnished with collars and glands, to receive without, add the suffix "WO" to the catalog number, "22V6H002-SOG-WO."

# Gauge Valves

## Pressures to 36,000 psi

**MAXIMATOR** Gauge Valves are designed and manufactured to exact standards, assuring the highest product quality and reliability for use in both the sour gas and sweet service applications. Sour Gas applications where H<sub>2</sub>S is present, use the "SOG" suffix (22,500 psig service).

For sweet service applications, the standard 316 material is preferred. These valves are engineered for high pressure line sampling and instrument calibration for working pressures to 36,000 psig.

### Ordering Information

Typical catalog number: **22GV9H008-SOG**

36GV	9H	07	8	-
Valve Series	O.D. Tube Size	Stem Type	Body Pattern	Connection Options
36GV	9H - 9/16"	07 - non-rotating Vee stem	8 - four-way, one on pressure	NO OPTION CHOSEN - standard service 316SS
22GV		00 - one piece k-Monel rotating Vee Stem		SOG - Sour Gas Service with annealed collars and glands SOGWO - Sour Gas Service without collars and glands

### Gauge Valve Features:

- Four 9/16" high pressure female connections are compatible with standard API test and gauge connections.
- Metal to metal stem and seat design provides bubble tight shut off.
- Valves available in both 316 cold worked, and 316 annealed stainless steel materials.
- Carbon reinforced PTFE packing with metal back-up rings located below the stem threads offers trouble free operation.
- Safety weep hole for all pressure connections and packing area.

Catalog Number	Pressure Rating (psi)	O.D. Tube (in.)	Con-nection Type	Service	Material	Dimensions (in.)									Valve Panel Hole
						A	B	C	D	E	F	H	J	K	
<b>Gauge Valves</b>															
36GV9H078	36,000	9/16	9HF	Standard	316 SS	4.55	2.00	1.34	1.06	2.95	1.38	1.32	2.57	3.88	1.00
22GV9H008-SOG	22,500			H <sub>2</sub> S	Annealed 316 SS										

G - Panel mounting screw thread size 10-24 UNC.

### Repair Kits

Consult your **HPT** representative for repair kits and valve bodies. Refer to the Tools and Installation section for proper maintenance procedures.

All SOG components are furnished with collars and glands, to receive without, add the suffix "WO" to the catalog number, "22V6H002-SOG-WO."

All dimensions are for reference only and are subject to change.

See page 2 in the Technical Section for pressure/temperature rating chart.

All general terms and conditions of sale, including limitations of our liability, apply to all products and services sold.

MT R1 0311

**Maximator** Bleed Valves are designed and engineered for use with Maximator Gauge Valves for high pressure venting before instrument calibration is performed. These valves can be purchased for both the sour gas and sweet service applications. Sour Gas applications where H<sub>2</sub>S is present, use the “SOG” suffix (22,500 psig).

For sweet service applications, the standard 316 material valve is preferred.

**NOTE: These bleed valves are designed for venting only. The 1/8” NPT outlet port must vent to atmosphere. If a pressureized outlet is required, HPT recommends using the 36V or 22V series needle valves for such piping applications.**

### Bleed Valve Features:

- 9/16” high pressure male connection compatible with standard API test and gauge connections.
- 1/8” NPTF tapped vent port for safe atmosphere plumbing.
- One piece stem design with positive blow out prevention.
- Stainless Steel Tee handle for ease of operation.
- One piece 316L body construction for ease of installation and corrosion resistance in a wide variety of applications.
- Safety weep hole in packing area.

Catalog Number	Pressure Rating (psi) Closed Position	O.D. Tube (in.)	Connection Type	Service	Material	Dimensions (in.)					
						A	B	C	D	E	F
<b>Bleed Valves</b>											
36BV9H002	36,000	9/16	9HF	Standard	316 SS	3.53	3.47	1.15	2.61	1.50	1.44
22BV9H002-SOG	22,500			H <sub>2</sub> S	Annealed 316 SS						

### Repair Kits

Consult your **HPT** representative for repair kits and valve bodies. Refer to the Tools and Installation section for proper maintenance procedures.

*All dimensions are for reference only and subject to change.  
See page 2 in the Technical Section for pressure/temperature rating chart.*

# Sour Gas Fittings

Pressures to 30,000 psi

**MAXIMATOR** Sour Gas fittings are designed for oil and gas service where H<sub>2</sub>S is present. All pressure containing components are made from annealed 316 stainless steel material in compliance with NACE MRO175. All High Pressure fittings are supplied with collars and glands. Mounting holes are standard on all elbows, tees and crosses.

Tubing Size (in.)	Gland	Collar	Plug	Tubing Cap
1/4	30G4H-SOG	30C4H-SOG	30P4H-SOG	30TC4H-SOG
3/8	30G6H-SOG	30C6H-SOG	30P6H-SOG	30TC6H-SOG
9/16	30G9H-SOG	30C9H-SOG	30P9H-SOG	30TC9H-SOG

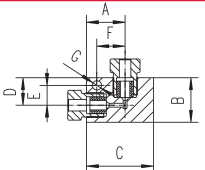
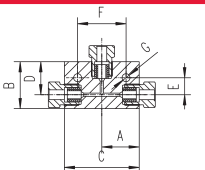
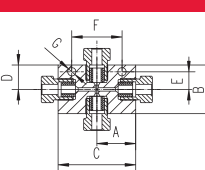
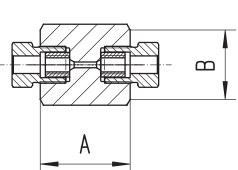
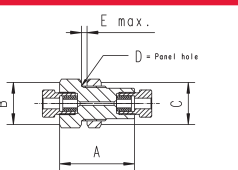
Fitting Pattern	Catalog Number	Conn. Type	O.D. Tube (in.)	Orifice (in.)	Dimensions (in.)							Block Thickness
					A	B	C	D	E	F	G	
<b>Elbow</b>												
	30L4H-SOG	4HF	1/4	0.094	0.89	1.02	1.54	0.63	0.46	0.65	0.22	1.02
	30L6H-SOG	6HF	3/8	0.125	1.26	1.50	2.01	0.98	0.72	0.69	0.26	1.02
	30L9H-SOG	9HF	9/16	0.188	1.89	1.89	2.64	1.10	0.83	0.94	0.33	1.54
<b>Tee</b>												
	30T4H-SOG	4HF	1/4	0.094	1.00	1.26	2.01	0.89	0.46	1.30	0.22	1.02
	30T6H-SOG	6HF	3/8	0.125	1.00	1.57	2.01	1.06	0.72	1.38	0.26	1.02
	30T9H-SOG	9HF	9/16	0.188	1.32	2.13	2.64	1.38	0.83	1.89	0.33	1.54
<b>Cross</b>												
	30X4H-SOG	4HF	1/4	0.094	1.00	1.26	2.01	0.63	0.46	1.30	0.22	1.02
	30X6H-SOG	6HF	3/8	0.125	1.00	2.13	2.01	1.06	0.72	1.38	0.26	1.02
	30X9H-SOG	9HF	9/16	0.188	1.32	2.76	2.64	1.38	0.83	1.89	0.33	1.54
<b>Straight Coupling/Union Coupling</b>												
	30F4H-SOG	4HF	1/4	0.094	1.38	1.06	Straight Coupling					
	30UF4H-SOG						Union Coupling					
	30F6H-SOG	6HF	3/8	0.125	1.77	1.06	Straight Coupling					
	30UF6H-SOG						Union Coupling					
	30F9H-SOG	9HF	9/16	0.188	2.19	1.44	Straight Coupling					
	30UF9H-SOG						Union Coupling					
<b>Bulkhead Coupling</b>												
	30BF4H-SOG	4HF	1/4	0.094	1.89	1.06	1.06	0.94	0.16	-	-	-
	30BF6H-SOG	6HF	3/8	0.125	2.38	1.44	1.44	1.18	0.35	-	-	-
	30BF9H-SOG	9HF	9/16	0.188	2.76	1.63	1.63	1.43	0.67	-	-	-

All dimensions are for reference only and subject to change.

See page 2 in the Technical Section for pressure/temperature rating chart.

8 All SOG components are furnished with collars and glands, to receive without, add the suffix "WO" to the catalog number, "22V6H002-SOG-WO."

All general terms and conditions of sale, including limitations of our liability, apply to all products and services sold.  
MT R1 0311



# Sour Gas Tubing and Nipples

## Pressures to 30,000 psi

**MAXIMATOR** Sour Gas Tubing is designed for oil and gas service where H<sub>2</sub>S is present. All tubing is seamless annealed 316 stainless steel material in compliance with NACE MR0175. This tubing is made under strict manufacturing and quality control standards and inspections, with dimensional tolerances to match the requirements of the high pressure coned and threaded connections.



### Tubing Tolerances

Normal Tubing Size (in.)	Tolerance O.D. (in.)
1/4	0.248 / 0.243
3/8	0.370 / 0.365
9/16	0.557 / 0.552

Catalog Number	Tube Material	Fits Connection Type	Tube Size (in.)		Working Pressure (psi)				
			O.D.	I.D.	-325 to 100°F	200°F	400°F	600°F	800°F
<b>30TU4H-316SOG</b>	316SS Annealed	4HF	1/4	0.083	30,000	27,000	24,900	22,800	21,600
<b>30TU6H-316SOG</b>	316SS	6HF	3/8	0.125	30,000	27,000	24,900	22,800	21,600
<b>30TU9H-316SOG</b>	316SS	9HF	9/16	0.188	30,000	27,000	24,900	22,800	21,600

All dimensions are for reference only and are subject to change.

See page 2 in the Technical Section for pressure/temperature rating chart.



**MAXIMATOR** offers ready made nipples with coned and threaded connections. All sour gas nipples are made from annealed 316 stainless steel material.

Catalog Numbers are 316 Stainless Steel material							Fits Connection Type	Tube Size (in.)		Working Pressure at 100 °F (psi)
2.75" Length	3" Length	4" Length	6" Length	8" Length	10" Length	12" Length		O.D.	I.D.	
<b>30N4H-2.75-316SOG</b>	<b>30N4H-3-316SOG</b>	<b>30N4H-4-316SOG</b>	<b>30N4H-6-316SOG</b>	<b>30N4H-8-316SOG</b>	<b>30N4H-10-316SOG</b>	<b>30N4H-12-316SOG</b>	4HF	1/4	0.083	30,000
	<b>30N6H-3-316SOG</b>	<b>30N6H-4-316SOG</b>	<b>30N6H-6-316SOG</b>	<b>30N6H-8-316SOG</b>	<b>30N6H-10-316SOG</b>	<b>30N6H-12-316SOG</b>	6HF	3/8	0.125	30,000
		<b>30N9H-4-316SOG</b>	<b>30N9H-6-316SOG</b>	<b>30N9H-8-316SOG</b>	<b>30N9H-10-316SOG</b>	<b>30N9H-12-316SOG</b>	9HF	9/16	0.188	30,000

All general terms and conditions of sale, including limitations of our liability, apply to all products and services sold.  
MT R1 0311

SOG nipples are not supplied with glands and collars, see Fittings on page 8 for these components.

See above tubing table for pressure/temperature rating chart.

All dimensions are for reference only and subject to change.

# Sour Gas Check Valves

Pressures to 30,000 psi

**O-Ring Check Valves**

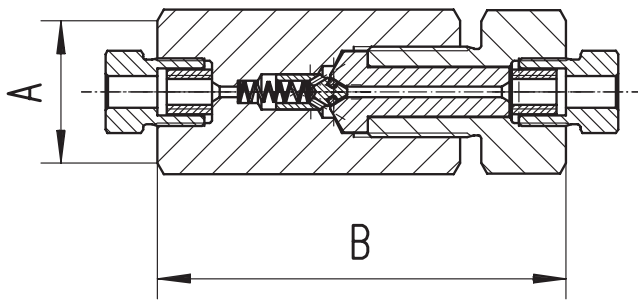

## Sour Gas O-Ring Check Valves

**MAXIMATOR** o-ring check valves provide high quality directional flow control and bubble tight shutoff for liquids and gases. These check valves are not to be used as a relief device. The cracking pressure of the o-ring check valves is approximately 10 psig.

**Materials.**

Body, cover, poppet, cover gland: annealed 316 stainless steel

Spring: Inconel X-750

O-ring: Viton "A" (-4 °F to 392 °F)

**Ball Check Valves**

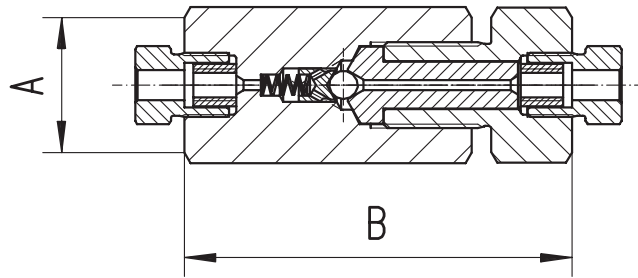

## Sour Gas Ball Check Valves

**MAXIMATOR** ball check valves prevent reverse flow where bubble tight shutoff is not mandatory. Check valves are designed to operate to 660 °F. These check valves are not to be used as a relief device. The cracking pressure of the o-ring check valves is approximately 10 psig.

**Materials.**

Body, cover, poppet, cover gland: annealed 316 stainless steel

Spring: Inconel X-750

Ball: 300 series stainless steel

Catalog Number	Connection Type	Pressure Rating (psi)	Orifice (in.)	Rated (Cv)	Dimensions (in.)	
					A (Hex.)	B
<b>Sour Gas O-Ring Check Valves</b>						
300C4H-SOG	4HF	30,000	0.094	0.15	1.19	3.40
300C6H-SOG	6HF	30,000	0.125	0.28	1.19	3.81
300C9H-SOG	9HF	30,000	0.187	0.63	1.63	4.61
<b>Sour Gas Ball Check Valves</b>						
30BC4H-SOG	4HF	30,000	0.094	0.15	1.19	3.40
30BC6H-SOG	6HF	30,000	0.125	0.28	1.19	3.81
30BC9H-SOG	9HF	30,000	0.187	0.63	1.63	4.61

**CAUTION:** FREQUENT INSPECTIONS of O-Rings are necessary to ensure proper service of the check valve. O-Rings have shown satisfactory service life in testing, however different service conditions may lead to variations in cycle and shelf life.

All SOG components are furnished with collars and glands, to receive without, add the suffix "WO" to the catalog number, "22V6H002-SOG-WO."

All general terms and conditions of sale, including limitations of our liability, apply to all products and services sold.  
MT R1 0311

## Sour Gas Dual-Disc Line Filters

**MAXIMATOR** dual-disc line filters are used to filter process fluids in high pressure systems. This design helps remove the large particles first through a coarse primary disc, which then allows a secondary disc to provide a smaller micron filtration. These filter elements are designed to withstand pressure surges without cracking, flaking, or rupturing. Filter elements come standard in the following micron sizes: 5/8, 8/30, 30/56 (secondary/primary). Filters are rated for temperatures -60 °F to 660 °F. All line filters come with glands and collars.

### Materials

Body: cover, cover gland: Annealed 316 series stainless steel  
Element: 300 series stainless steel

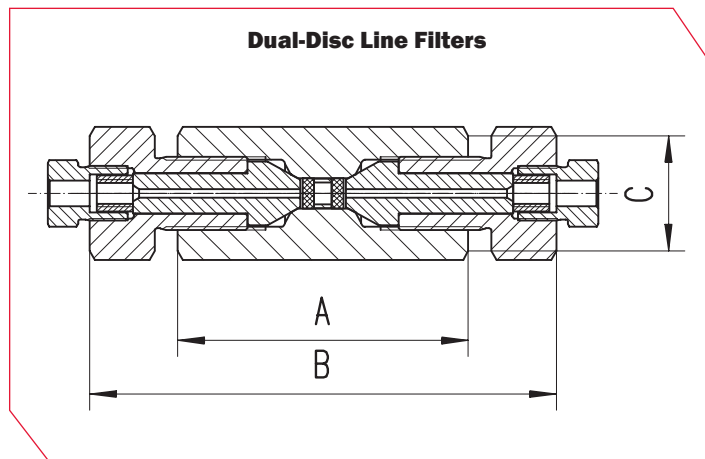

## Sour Gas Cup-Type Line Filters

**MAXIMATOR** cup-type line filters are used when maximum filtration surface area and a single micron size element is preferred. This design increases the filter area as much as 6 times the area of the disc type filter, and will permit higher flow rates with a lower pressure drop, and longer intervals between element changes. Filter elements come standard in 5, 30, or 56 micron sizes and are easily replaced. Filters are rated for temperatures -60 °F to 660 °F. All line filters come with glands and collars.

### Materials:

Body, cover, cover gland: Annealed 316 series stainless steel  
Element: 300 series stainless steel

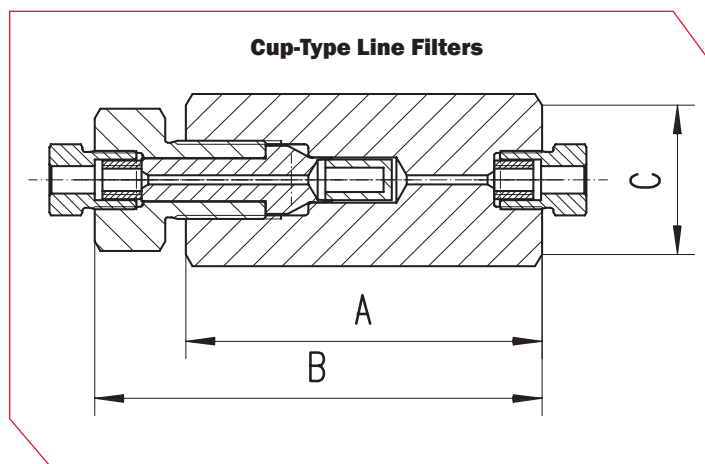

Catalog Number	Pressure Rating (psi)	Orifice (in.)	Micron Size	Connection Type	Filter Element Area (in. <sup>2</sup> )	Dimensions (in.)		
						A (Hex.)	B	C
<b>Dual-Disc Line Filters</b>								
30DF4H-5/8-SOG	30,000	0.094	5/8	4HF	0.07	2.99	4.81	1.19
30DF4H-8/30-SOG			8/30					
30DF4H-30/56-SOG			30/56					
30DF6H-5/8-SOG	30,000	0.125	5/8	6HF	0.07	2.99	5.18	1.19
30DF6H-8/30-SOG			8/30					
30DF6H-30/56-SOG			30/56					
30DF9H-5/8-SOG	30,000	0.187	5/8	9HF	0.15	3.39	5.73	1.44
30DF9H-8/30-SOG			8/30					
30DF9H-30/56-SOG			30/56					
<b>Cup-Type Line Filters</b>								
30CF4H-5-SOG	30,000	0.094	5	4HF	0.82	3.39	4.25	1.44
30CF4H-30-SOG			30					
30CF4H-56-SOG			56					
30CF6H-5-SOG	30,000	0.125	5	6HF	0.82	2.39	4.44	1.44
30CF6H-30-SOG			30					
30CF6H-56-SOG			56					
30CF9H-5-SOG	30,000	0.187	5	9HF	0.82	4.06	5.28	1.63
30CF9H-30-SOG			30					
30CF9H-56-SOG			56					

All SOG components are furnished with collars and glands, to receive without, add the suffix "WO" to the catalog number, "22V6H002-SOG-WO."

All dimensions for reference only and are subject to change.

NOTE: It is recommended that all liquids entering a high pressure system be thoroughly cleaned, maximator filters are designed to remove small amounts of process particles. Pressure differential should not exceed 1000 psi across the filter elements.

All general terms and conditions of sale, including limitations of our liability, apply to all products and services sold.  
MT R1 0311

# Sour Gas Adapters & Couplings

## Pressures to 30,000 psi

**MAXIMATOR** sour gas adapters and couplings are designed to join a variety of pressure connections where H<sub>2</sub>S is present. All adapters are made of annealed 316 stainless steel material that meets NACE MRO175 specification. If collars and glands are not required, simply add "-WO" to the catalog numbers below.

### Instructions

Find the male connection you want on the adapter in the "A" column and the female connection of the adapter in the "B" column. At the intersection of the two columns is the appropriate catalog number.



### Adapter (male x female)

Pressure Series	Male Connection "A"			Female High Pressure 30,000 psi		
	Tube Size (in.)	Connection Type	Maximum Pressure (psi)*	1/4" 4HF	3/8" 6HF	9/16" 9HF
Male High	1/4	4HM	30,000		30A4H6H-SOG	30A4H9H-SOG
	3/8	6HM	30,000	30A6H4H-SOG		30A6H9H-SOG
	9/16	9HM	30,000	30A9H4H-SOG	30A9H6H-SOG	
Male Pipe	1/8	MNPT	10,000	30A2P4H-SOG	30A2P6H-SOG	30A2P9H-SOG
	1/4	MNPT	10,000	30A4P4H-SOG	30A4P6H-SOG	30A4P9H-SOG
	3/8	MNPT	10,000	30A6P4H-SOG	30A6P6H-SOG	30A6P9H-SOG
	1/2	MNPT	10,000	30A8P4H-SOG	30A8P6H-SOG	30A8P9H-SOG
	3/4	MNPT	10,000	30A12P4H-SOG	30A12P6H-SOG	30A12P9H-SOG
	1	MNPT	10,000	30A16P4H-SOG	30A16P6H-SOG	30A16P9H-SOG

### Couplings (female x female)

Pressure Series	Female Connection "A"			Female High Pressure 30,000 psi		
	Tube Size (in.)	Connection Type	Maximum Pressure (psi)*	1/4" 4HF	3/8" 6HF	9/16" 9HF
Female High	1/4	4HM	30,000	30F4H-SOG	30F4H6H-SOG	30F4H9H-SOG
	3/8	6HM	30,000		30F6H-SOG	30F6H9H-SOG
	9/16	9HM	30,000			30F9H-SOG

### Adapters (male x male)

Pressure Series	Male Connection "A"			Male High Pressure 30,000 psi		
	Tube Size (in.)	Connection Type	Maximum Pressure (psi)*	1/4" 4HF	3/8" 6HF	9/16" 9HF
Male High	1/4	4HM	30,000	30M4H-SOG	30M4H6H-SOG	30M4H9H-SOG
	3/8	6HM	30,000		30M6H-SOG	30M6H9H-SOG
	9/16	9HM	30,000			30M9H-SOG

# Sour Gas Adapters, Couplings

Pressures to 30,000 psi



## Female Connection "B"

Female Pipe 10,000 psi						
1/8" FNPT	1/4" FNPT	3/8" FNPT	1/2" FNPT	3/4" FNPT	1" FNPT	
<b>10A4H2P-SOG</b>	<b>10A4H4P-SOG</b>	<b>10A4H6P-SOG</b>	<b>10A4H8P-SOG</b>	<b>10A4H12P-SOG</b>	<b>10A4H16P-SOG</b>	
<b>10A6H2P-SOG</b>	<b>10A6H4P-SOG</b>	<b>10A6H6P-SOG</b>	<b>10A6H8P-SOG</b>	<b>10A6H12P-SOG</b>	<b>10A6H16P-SOG</b>	
<b>10A9H2P-SOG</b>	<b>10A9H4P-SOG</b>	<b>10A9H6P-SOG</b>	<b>10A9H8P-SOG</b>	<b>10A9H12P-SOG</b>	<b>10A9H16P-SOG</b>	

## Female Connection "B"

Female Pipe 10,000 psi						
1/8" FNPT	1/4" FNPT	3/8" FNPT	1/2" FNPT	3/4" FNPT	1" FNPT	
	<b>10F4H4P-SOG</b>	<b>10F4H6P-SOG</b>	<b>10F4H8P-SOG</b>	<b>10F4H12P-SOG</b>	<b>10F4H16P-SOG</b>	
	<b>10F6H4P-SOG</b>	<b>10F6H6P-SOG</b>	<b>10F6H8P-SOG</b>	<b>10F6H12P-SOG</b>	<b>10F6H16P-SOG</b>	
	<b>10F9H4P-SOG</b>	<b>10F9H6P-SOG</b>	<b>10F9H8P-SOG</b>	<b>10F9H12P-SOG</b>	<b>10F9H16P-SOG</b>	

## Male Connection "B"

Male Pipe 10,000 psi						
1/8" FNPT	1/4" FNPT	3/8" FNPT	1/2" FNPT	3/4" FNPT	1" FNPT	
	<b>10M4H4P-SOG</b>	<b>10M4H6P-SOG</b>	<b>10M4H8P-SOG</b>	<b>10M4H12P-SOG</b>	<b>10M4H16P-SOG</b>	
	<b>10M6H4P-SOG</b>	<b>10M6H6P-SOG</b>	<b>10M6H8P-SOG</b>	<b>10M6H12P-SOG</b>	<b>10M6H16P-SOG</b>	
	<b>10M9H4P-SOG</b>	<b>10M9H6P-SOG</b>	<b>10M9H8P-SOG</b>	<b>10M9H12P-SOG</b>	<b>10M9H16P-SOG</b>	

All dimensions for reference only and are subject to change.

All general terms and conditions of sale, including limitations of our liability, apply to all products and services sold.  
MT R1 0311

\* The pressure rating of any adapter is the value of the lowest rated connection in the fitting.