

MAXIMATOR® Maximum Pressure.

High Pressure Technology • Testing Equipment
Hydraulics • Pneumatics



Contact Sales: (661) 251-5069

Technical Data Sheet

Hydraulic Driven Booster

Type HDLE 30

Available Models:

- double acting, single stage
- double acting, single stage, double stroke length

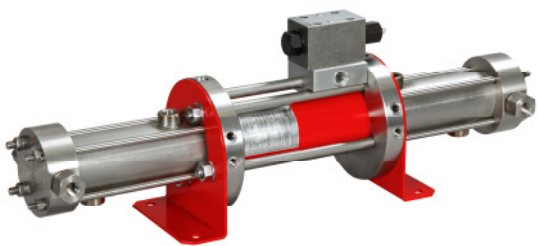

figure similar

Technical Data:

Maximum hydraulic drive pressure pH	210 bar / 3.045 psi
Maximum hydraulic flow rate	30 l/min
Pressure ratio i	1:4
Minimum gas inlet pressure pA min.	15 bar / 218 psi
Maximum gas inlet pressure pA max.	900 bar / 13.050 psi
Maximum gas outlet pressure pB	900 bar / 13.050 psi
Displacement volume	120 cm ³
Maximum cycles	60 / min
Stroke length	97 mm

Pressure and flow performances, please see enclosed graph.

Standard connections

Hydraulic drive	1/4" BSP
Gas Inlet	1/4" BSP
Gas Outlet	9/16-18 UNF
Max. operating temperature	60°C
Weight	22 kg

Approximate Dimensions:

Height:	208 mm
Length:	622 mm
Width:	145 mm

Options:

Inert Gas Flushing for applications with explosive or dangerous gases	
CO2 service	Seal Package: PTFE, NBR

Hydraulic Drive System:

Customized Hydraulic Booster Station

Hydraulic boosters are delivered as complete packages (including the hydraulic supply unit). Through compact and modular construction, the HDLE is able to conform miscellaneous requirements. Available constructions are for example multi-stage applications as well as parallel or single applications.

The hydraulic supply unit can be supplied with fixed displacement pump or variable capacity pump and electric motor. The electrical control system ensures that the hydraulic booster shuts down on reaching the preset operating pressure. As an option, pressure inlet and pressure outlet can be supplied with shut-off valves, pressure gauges and pressure switches. More information is summarized on page 3.

Please consult factory for more information. All technical and dimensional information subject to change. All General Terms and Conditions of sale, including limitations of our liability, apply to all products and services sold.



Dimensional Drawing

HDLE 30

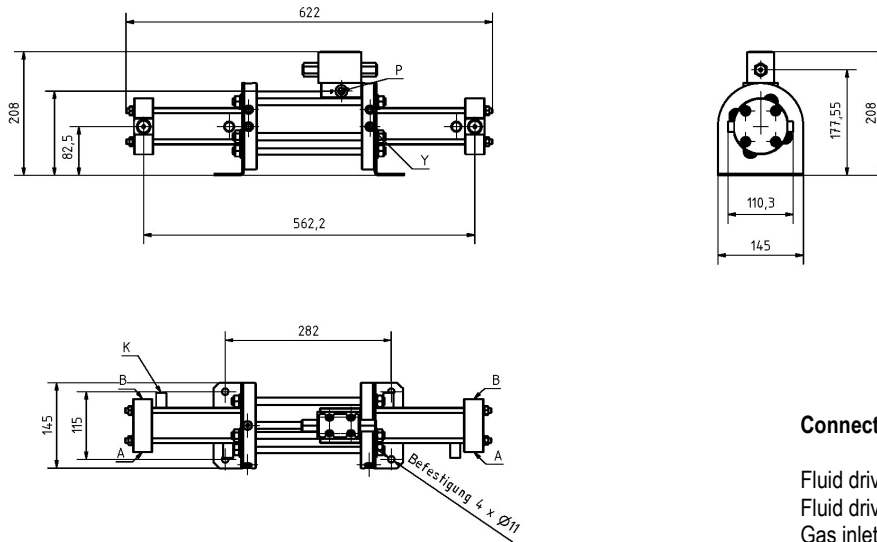

Connections:

- | | |
|----------------------|----------------|
| Fluid drive inlet | P = BSP 1/4" |
| Fluid drive outlet | T = BSP 1/4" |
| Gas inlet | A = BSP 1/4" |
| Gas outlet | B = 9/16-18UNF |
| Flushing connection | Y = BSP 1/8" |
| Cooling inlet/outlet | K = BSP 3/8" |

Performance Graph

HDLE 30

Leistungsdiagramm HDLE 30
Performance Graph HDLE 30

NOTE: The flow capacity of HDLE remains constant over the entire pressure range.

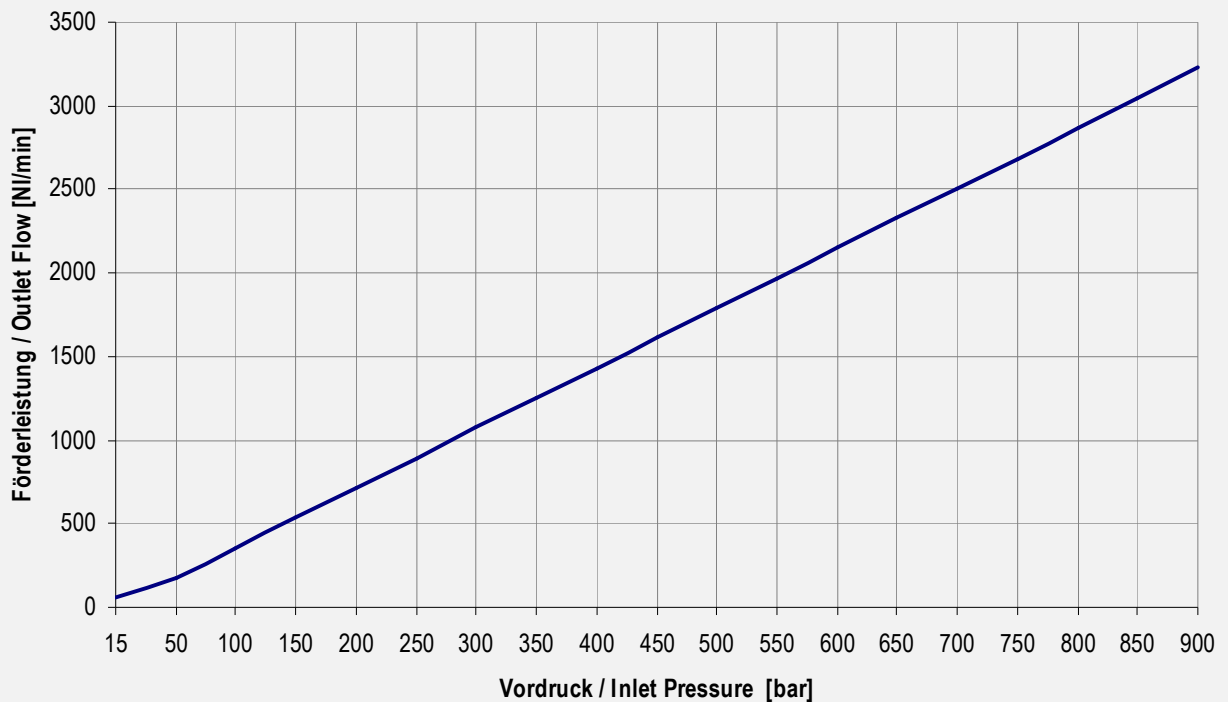

MAXIMATOR® Maximum Pressure.

High Pressure Technology • Testing Equipment
Hydraulics • Pneumatics



Contact Sales: (661) 251-5069

Technical Data Sheet

Hydraulic Booster Station



figure similar

Characteristic Features

- hydraulic supply unit with fixed displacement pump or variable capacity pump and electric motor
- electrical control system for shut down on reaching preset operating pressure
- shut-off valves, pressure gauges and pressure switches for pressure inlet and outlet
- air- or water cooler

Options

- Nitrogen flushing for handling of not inert gases
- Frequency converter for speed control
- thermostatic control for oil-air cooling

Pressure ranges:

- HDLE 2 up to 50 bar
- HDLE 5 up to 100 bar
- HDLE 15 up to 300 bar
- HDLE 30 up to 900 bar

Technical Data

Inlet pressure P_V 2-900 bar

Working pressure P max. 900 bar

Examples for Flow capacities

HDLE 5 with double stroke length

Inlet Pressure	Outlet Pressure	Flow capacity
$P_V = 4$ bar	$P = 100$ bar	$Q \approx 80$ NI/min
$P_V = 12$ bar	$P = 100$ bar	$Q \approx 520$ NI/min
$P_V = 50$ bar	$P = 100$ bar	$Q \approx 2200$ NI/min

HDLE 15 with double stroke length

Inlet Pressure	Outlet Pressure	Flow capacity
$P_V = 10$ bar	$P = 300$ bar	$Q \approx 140$ NI/min
$P_V = 80$ bar	$P = 300$ bar	$Q \approx 1150$ NI/min
$P_V = 150$ bar	$P = 300$ bar	$Q \approx 2100$ NI/min

HDLE 30 with double stroke length

Inlet Pressure	Outlet Pressure	Flow capacity
$P_V = 100$ bar	$P = 900$ bar	$Q \approx 650$ NI/min
$P_V = 300$ bar	$P = 900$ bar	$Q \approx 2000$ NI/min
$P_V = 600$ bar	$P = 900$ bar	$Q \approx 4000$ NI/min

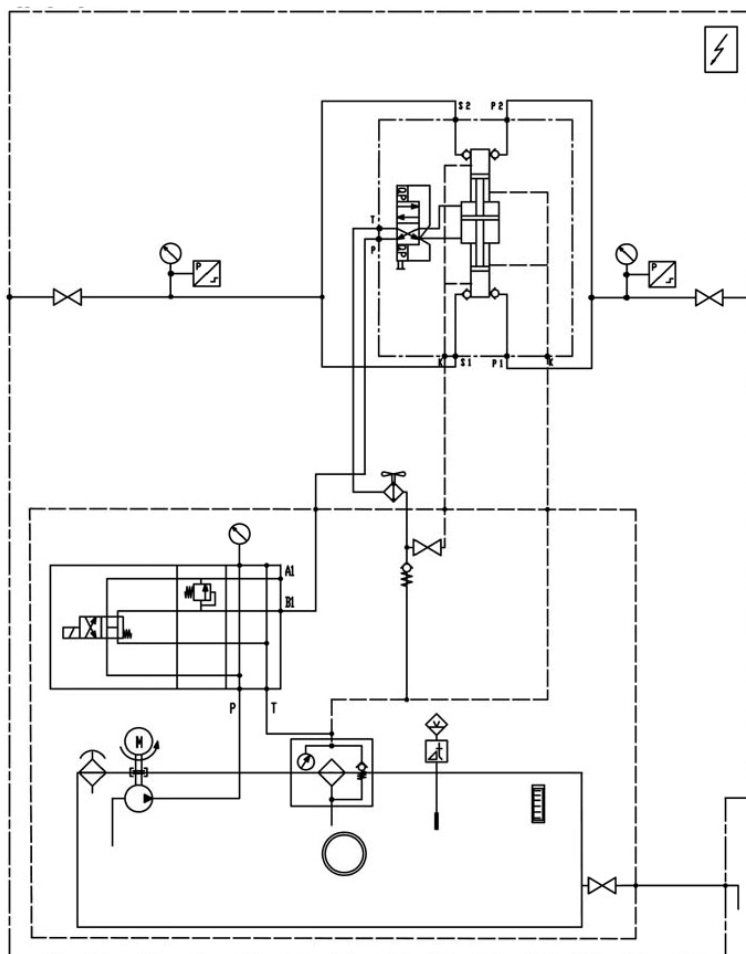

MAXIMATOR®

Maximum Pressure.

High Pressure Technology • Testing Equipment
Hydraulics • Pneumatics



High Pressure Technologies, LLC.

HPT



Contact Sales: (661) 251-5069

