

Assembly Instructions for High-Pressure Pumps

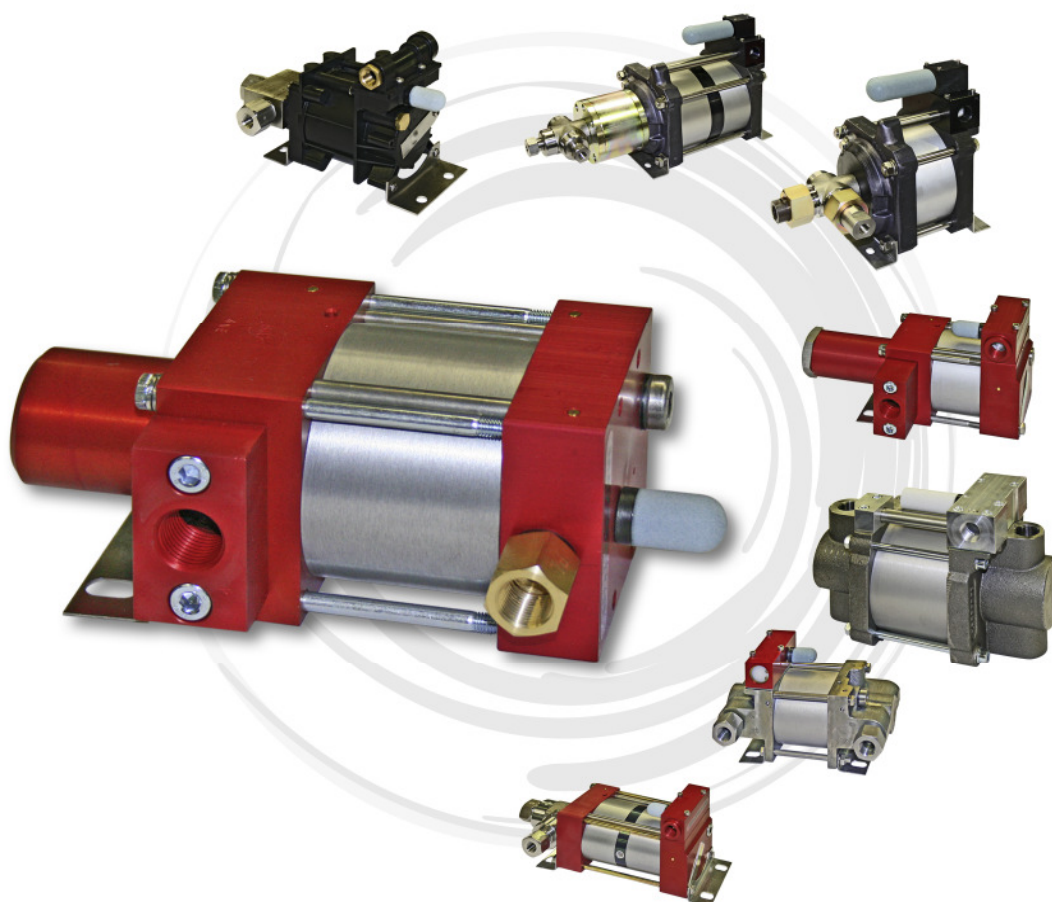

MAXIMATOR®
Maximum Pressure.



MAXIMATOR GmbH
Lange Straße 6 • D-99734 Nordhausen
Tel.: 0 36 31 / 95 33-0 • Fax: 0 36 31 / 95 33-5010
e-mail: info@maximator.de
Internet: <http://www.maximator.de>

© Copyright of the issuer:

These assembly instructions may only be reproduced, translated or made accessible to third parties with the issuer's express consent.



Table of Contents

1	Basic Information.....	1
1.1	Notes on the Assembly Instructions.....	1
1.2	Intended Use.....	2
1.3	Warranty and Liability.....	2
2	Safety Instructions.....	3
2.1	General Safety Directives.....	3
2.2	Symbols and Signal Terms.....	4
2.3	Basic Safety Measures.....	4
2.3.1	Technical condition.....	4
2.3.2	Safety instructions for operation.....	5
2.3.3	Safety instructions for maintenance and repair work.....	5
2.3.4	Requirements on staff.....	6
2.4	Special Safety Instructions.....	6
2.4.1	Safety in the event of emissions.....	6
2.4.2	Safety in the event of defective equipment.....	7
2.4.3	Safety at the installation location.....	7
3	Technical Description.....	8
3.1	How a High-Pressure Pump Works.....	8
3.2	Overview of High-Pressure Pumps.....	11
3.3	Models.....	14
3.4	Type Designation Code.....	14
4	Assembly and Putting into Service.....	15
4.1	General Assembly Information.....	15
4.2	Compressed Air System.....	15
4.2.1	Compressed air lubricator.....	16
4.2.2	Pipe cross-sections.....	16
4.2.3	Direct pilot-valve air.....	17
4.3	Hydraulics System.....	17
4.3.1	Intake pipe.....	17
4.3.2	Pressure pipe.....	18
4.3.3	Pumping medium.....	18



Table of Contents

4.4	Putting into Service	18
5	Servicing and Maintenance.....	19
5.1	Maintenance Information.....	19
5.2	Maintenance	19
5.2.1	Pressure System.....	19
5.2.2	Hydraulics System	20
5.3	Repair	21
5.3.1	Warranty	22
6	Technical Data	23



1 Basic Information

MAXIMATOR's high-pressure pumps can be used for a large number of applications. Their purpose is to generate high pressures with oil or water. The pumps are driven by compressed air at a range of 1 to 10 bars.

1.1 Notes on the Assembly Instructions

These assembly instructions describe how to set up the pumps and provide information about how to assemble and maintain them properly. Read the assembly instructions carefully before actually using the pumps.

The assembly instructions facilitate rapid understanding of the technical details and contain all the necessary information on how to use the pumps.

The instructions contain technical data, a technical description and information on how to commission, operate and maintain the pumps.

Technical data and measurement and weight information apply to the day on which these assembly instructions were printed. They may differ in detail from a particular implementation, without fundamentally changing the objective information and thereby losing validity. Differences in textual and pictorial statements depend on equipment and accessories, which means that no claims arising from this can be asserted. All maintenance, assembly and operating information prescribed in these assembly instructions must be complied with to ensure full functionality and safety. The pumps are intended only for the purposes mentioned in the assembly instructions. The manufacturer cannot recognize claims caused by incorrect operation and inadequate maintenance.

The attached documents relating to documents and all other documents that are part of the scope of delivery must be observed.

The relevant accident prevention regulations and other generally recognized safety requirements must be complied with.



1.2 Intended Use

The pumps must be used exclusively for media for which they are suited according to the media resistance list. Other media must be tested in respect of their compatibility with the pump materials prior to their use. The drive of the pumps is designed for compressed air up to 10 bars. Other drive media must likewise be tested in respect of their compatibility with the pump materials.

Pump changes and conversions are not permitted, for reasons of safety. The pump is not designed for extended dry running (without pumping medium). Extended dry running would cause the lubricating film in the high-pressure part to tear off. Dry running over a shorter period of time (e.g. during venting) is harmless.

1.3 Warranty and Liability

In principle, the "General Conditions of Sale and Delivery" supplied by the manufacturer of the pumps shall apply.

Warranty and liability claims in case of personal or property damage shall be precluded if they are due to one or more of the following causes:

- Abnormal use of the pumps.
- Incorrect putting into service, operation or maintenance of the pumps.
- Changes to the pumps.
- Operating the pumps with defective safety devices or incorrectly installed safety and protective devices.
- Failure to comply with the information in these instructions in respect of putting into service, operation and maintenance.
- Inadequate surveillance of pump parts that are subject to abrasion.
- Incorrect repair work.



2 Safety Instructions

2.1 General Safety Directives

The following EC Directives apply to the safety of the machinery:

- Machinery Directive 2006/42/EC, Annex II No.1 B

and applied harmonized standards

- EN ISO 12100-1 and 12100-2

The pumps may be the source of hazards if they are used by untrained staff, or are used incorrectly or abnormally.

Each person that is instructed to operate or maintain the pumps must have read and understood the complete assembly instructions before carrying out the corresponding activities. This also applies if the person in question has already operated, or received training for, the pumps.

We recommend that the operating company should obtain written confirmation from staff that they are familiar with the assembly instructions. Familiarity with the content of the assembly instructions is one of the prerequisites for protecting people against hazards and for avoiding errors and hence for operating the pumps safely and without malfunction. The assembly instructions must be available to operators and maintenance staff at all times! The operating company, or staff authorized by it to use the pumps within the scope of their duties, is responsible for ensuring accident-free operation.

Work safety-related data is based on currently valid directives issued by the European Community. In other countries, the relevant laws and regulations must be complied with. The operating company must determine the current status of all regulations both for the European Community and for other countries. Apart from the work safety information in these assembly instructions, generally accepted safety and accident prevention regulations must be observed and complied with.

All information given in the assembly instructions must be observed unconditionally!

2.2 Symbols and Signal Terms



HAZARD

Type and source of hazard
Hazards that may result in serious bodily injuries or even death.
Hazard avoidance measures.



CAUTION

Type and source of hazard
Hazards that may result in bodily injuries or property damage.
Hazard avoidance measures.



NOTE

User tips and useful information.



NOTE

Environmental impact

2.3 Basic Safety Measures

2.3.1 Technical condition

The following must be observed:

- To avoid hazards and to ensure optimal performance, no modifications or conversions must be made to the pumps.
- The user is obliged to ensure that the pumps are operated when in perfect working condition and safe to operate. The technical condition of the pumps must comply with statutory requirements and regulations.
- Each time before the pumps are put into service, checks must be performed to ensure that the pumps are not damaged and are in proper condition.
- Any changes to the pumps that affect safety must be reported by staff to the operating company.

2.3.2 Safety instructions for operation

Each time before the pumps are put into service, checks must be performed to ensure that they are operationally safe.

The following safety instructions must be observed when operating the pumps:

- Generally accepted safety and accident prevention regulations must be observed!
- Staff must be familiar with all devices and actuators and how they function before putting the pumps into service!
- Exercise caution with all hydraulically activated parts
- During the entire operation, always ensure that operating conditions are suitable for deployment of the pumps.
- Shut down the pumps immediately if you observe changes during operation.



CAUTION

Make sure that you depressurize the drive and high-pressure parts of the pumps before working on them.



CAUTION

Adjustment and repair work may only be undertaken by specialist workshops!

2.3.3 Safety instructions for maintenance and repair work

Operating malfunctions brought about by inadequate or incorrect maintenance may also cause substantial repair costs and long downtimes.

The manufacturer accepts no liability for damage resulting from incorrect maintenance and care!

The maintenance intervals are laid down in a maintenance schedule.

The following must be observed:

- The pumps may only be maintained and repaired by the manufacturer's service team or by specially trained and instructed specialised personnel.
- All maintenance and repair work must be performed when the pumps are switched off and depressurized.



2.3.4 Requirements on staff

- Prior to commencing work, staff must be instructed in the hazards connected with handling the pumps.
- The pumps may pose injury hazards if operated by untrained staff.
- Any person instructed to put into service, maintain or repair the pumps must have read and understood the assembly instructions in their entirety.
- The assembly instructions must be available to staff at all times. We recommend that you obtain written confirmation from staff that they are familiar with the contents of the assembly instructions.
- Staff must wear protective clothing as directed by the operating company.
- All safety information contained in these assembly instructions and in all other documents must always be fully observed and complied with.
- If hazards that might result in personal injury are identified, the pump must be shut down immediately.
- Staff must have sound knowledge of the following operating processes, regulations and procedures:
 - Operating procedures for the pumps
 - Protective fencing, safeguards and signs in the danger zone.
 - Behaviour and measures to be taken in the event of hazards.

2.4 Special Safety Instructions

2.4.1 Safety in the event of emissions

Depending on use, some noise build-up can be expected, due to the expanding compressed air. Air escaping from the silencer may be soiled by water, oil or grease.

Small ice crystals, which may come loose and fly away, may also form on the silencer. Staff located in the environment of operating pumps must wear protective goggles and, where applicable, hearing protection.

2.4.2 Safety in the event of defective equipment

During operation of the pumps, the drive part and the high-pressure part are under pressure. The escaping gases or liquids are subjected to high pressure if there is a defect or even during normal operation. They must not be intercepted or restrained by objects or body parts. You must ensure, in the event of a defect, that the pump is immediately depressurized and repaired.



HAZARD

Maintenance and repair work may only be carried out on depressurized equipment.

2.4.3 Safety at the installation location

The pumps must not be operated in enclosed vessels. The escaping drive air may cause the vessel to burst.

Hydraulic bolted unions on intake and pressure nozzles must not be loosened.

Bolted unions must be tight to prevent leaks and damage. The pump must be installed in a way that keeps the actuators and bolted unions freely accessible at all times.



3 Technical Description

MAXIMATOR pumps work according to the pressure intensifier principle. Large areas are charged with a low pressure (air piston) and generate high pressure (plunger piston) over the small surface areas. Continuous pumping is achieved by means of sustained pulsation. Pulsation is generated by a 4/2 directional control valve (control slide valve). The 4/2 directional control valve is controlled by impulses. The control slide valve alternately applies pressure to the top and bottom of the air piston. The control slide valve is selected by two 2/2 directional control valves (pilot valves), which are mechanically actuated by the air piston in its stop positions. The pilot valves aerate and ventilate the actuation compartment of the control slide valve, the reaction force for the control slide valve being provided by the drive air. The control slide valve has a larger effective area in the actuation compartment than in the control compartment, to which compressed air is continually applied. The plunger piston uses check valves (intake valve, pressure valve) to generate the volumetric flow. The outlet pressure results from the pressure ratio between air piston and plunger piston, multiplied by the drive pressure.

A static hydraulics end pressure can be configured by regulating the drive pressure. The pump stops when it reaches the final pressure, ceasing to use any more air. Only if there is a drop in pressure on the hydraulics side or a rise in pressure on the drive side, does the pump-re-start. Pumps for manual emergency operation constitute an exception. With these pumps, the intake stroke is performed by a spring (only for pumps M22 to M189). All pumps are single-acting. They have a high-pressure part and an air piston. If the pump performs an intake stroke, no liquid is conveyed. A pulsating flow rate is created. Virtually all pumps can also be built with two high-pressure parts in a double-acting design. This increases output capacity and decreases pulsation. A number of single-acting pumps can also be equipped with two or three air pistons. This doubles or trebles the nominal pressure ratios. A higher hydraulic pressure is achieved using less drive pressure.

3.1 How a High-Pressure Pump Works

Drive air flows from the port (8) through the control slide valve (10) to the bottom of the air piston (11). The pump performs an intake stroke. The intake valve (3) opens. The plunger piston (4) sucks the liquid through the intake port (2) to the HP part of the pump. In the upper stop position, the air piston (11) actuates the pilot valve (12). Control air passes from the port (7) to the control slide valve (10) and pushes it into the other switching position.

The compartment below the air piston (11) is connected via the control slide valve (10) to the silencer (9). Drive air simultaneously accesses the top of the air piston (11). The pressure stroke is performed. The intake valve (3) closes. The pressure valve (5) is opened and the plunger piston (4) pushes the pumping medium from the pressure outlet (6). During the pressure stroke, both pilot valves (1) and (12) are closed. The control slide valve (10) is held in its front position by the trapped pressure on the large control slide valve side. If the air piston (11) reaches the bottom stop position, it actuates the pilot valve (1). The large control slide valve area is ventilated via the port (Y). The control slide valve (10) is pushed into the start position by the drive air. A new intake stroke begins.

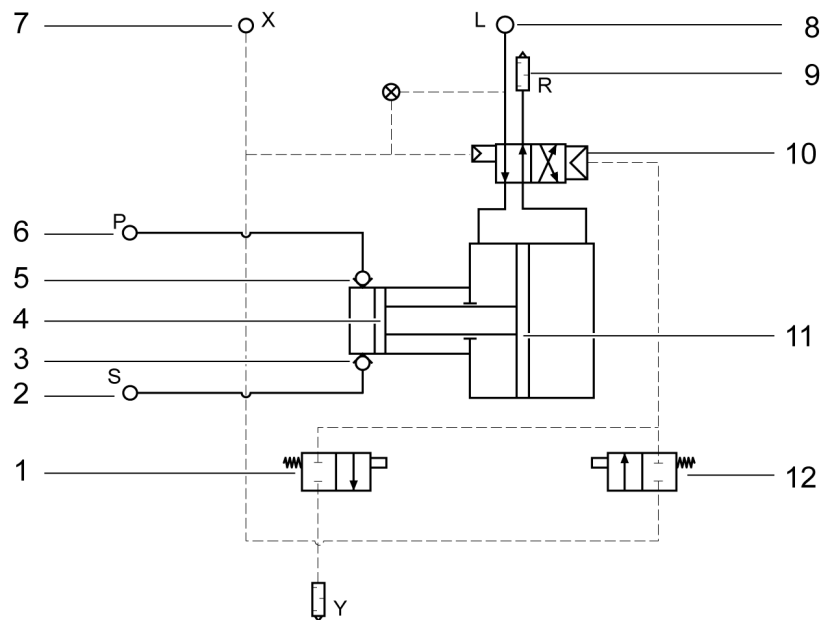

Figure. 1: Working principle of a high-pressure pump

- | | | | |
|---|-----------------------|----|---------------------|
| 1 | Ventilate pilot valve | 7 | Control air inlet |
| 2 | Intake port | 8 | Air port |
| 3 | Inlet valve | 9 | Output air outlet |
| 4 | Plunger piston | 10 | Control slide valve |
| 5 | Outlet valve | 11 | Air piston |
| 6 | Pressure outlet | 12 | Aerate pilot valve |

Technical Description

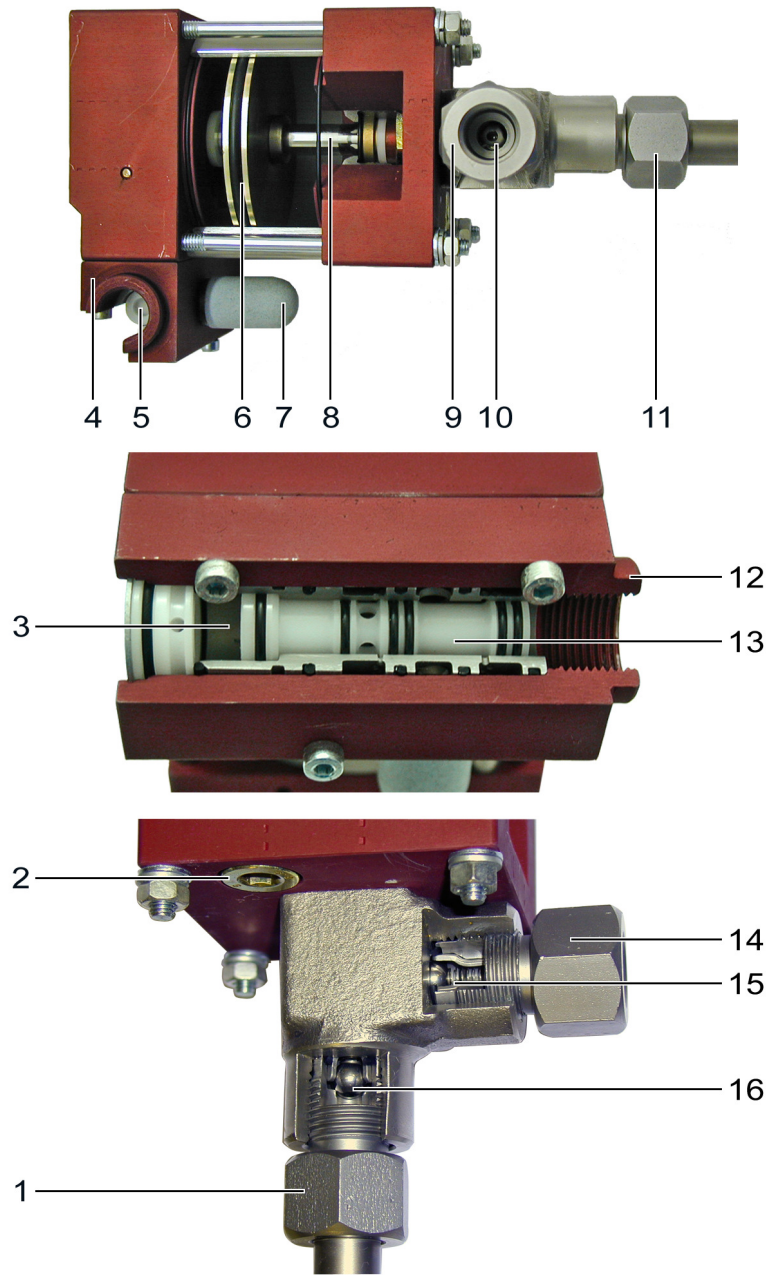
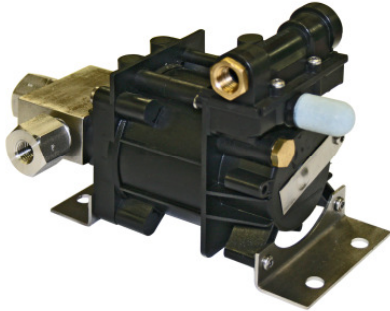
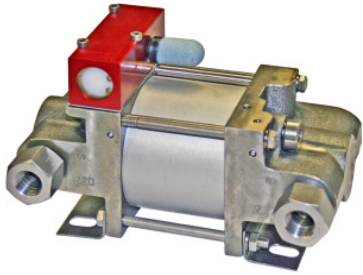
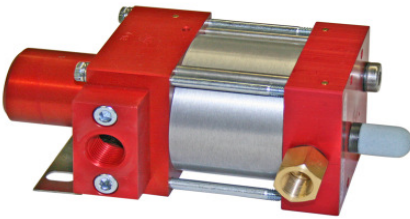
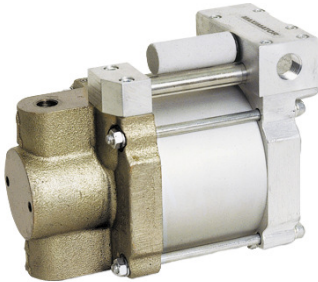
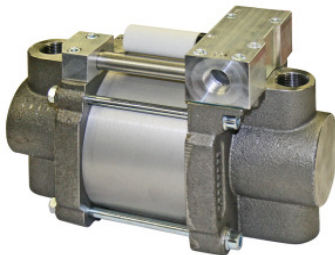

Fig. 2: High-pressure pump subassemblies (example)

- | | | | |
|---|-----------------------|----|---------------------|
| 1 | Intake port | 9 | Pressure outlet |
| 2 | Pilot valve | 10 | Outlet valve |
| 3 | Actuation compartment | 11 | Intake port |
| 4 | Air port | 12 | Air port |
| 5 | Control slide valve | 13 | Control slide valve |
| 6 | Air piston | 14 | Pressure outlet |
| 7 | Drive air outlet | 15 | Outlet valve |
| 8 | Plunger piston | 16 | Intake valve |

3.2 Overview of High-Pressure Pumps

Designation	Figure	Area of application
MP mini-pump		<p>Pumps for oil up to 1000 bars.</p> <ul style="list-style-type: none"> <input type="checkbox"/> Lifting and clamping Hydraulic systems for lifting and moving loads, lifting tables, scissor-type jacks. <input type="checkbox"/> Hydraulic applications Clamping devices, stamping machines and presses, clamping chucks, actuation of hydraulic cylinders.
MO mini-pump		<ul style="list-style-type: none"> <input type="checkbox"/> Presses Cold isostatic presses, filter presses, hydraulic presses, pressure generation for presses and press overload protectors. <input type="checkbox"/> Tools Actuation of cutting and folding devices, cable shears, pipe bending devices, clamping cylinders, actuation of torque wrenches. <input type="checkbox"/> Testing Test machines for pressure and tensile strength tests.
		
S standard pump		<ul style="list-style-type: none"> <input type="checkbox"/> Lubricating systems
		

Technical Description

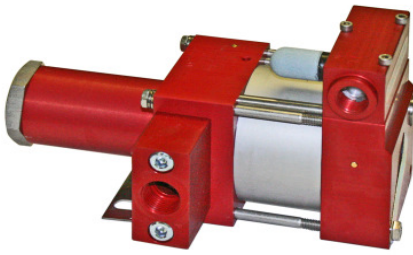
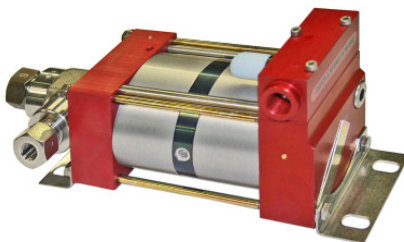
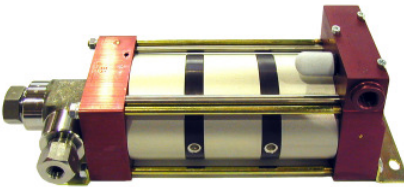
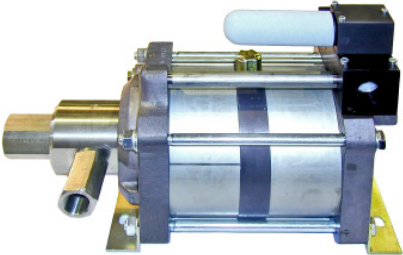
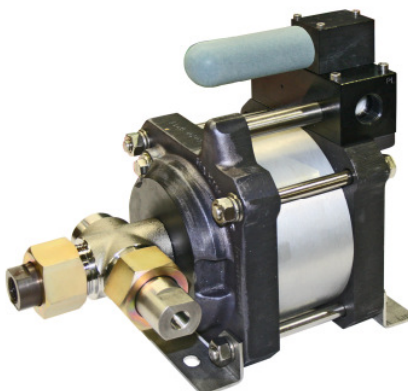
Designation	Figure	Area of application
<p>M mini-pump</p>		<p>Pumps for water and oil up to 5500 bars. Models: Single and double-acting, one-, two- and three-stage.</p> <ul style="list-style-type: none"> <input type="checkbox"/> Hydrostatic tests on: Valves, tanks, accumulators, pressure switches, measuring transducers, manometers, shut-off devices for boreholes, components for aircraft and aerospace technology. <input type="checkbox"/> Burst pressure and endurance test for the listed parts. <input type="checkbox"/> Calibration of manometers and measuring transducers <input type="checkbox"/> Water-jet cutting and cleaning <input type="checkbox"/> Leakage tests <input type="checkbox"/> Emergency-stop systems for oil and gas platforms <input type="checkbox"/> Pressurization of pressure accumulators
		
		
<p>G high-output pump</p>		
		

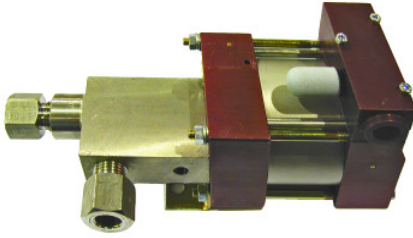
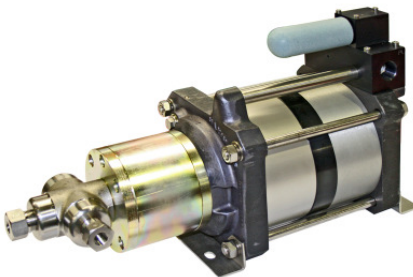
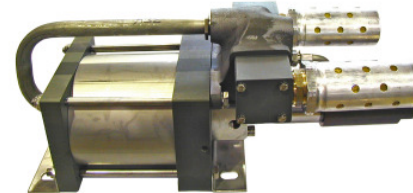
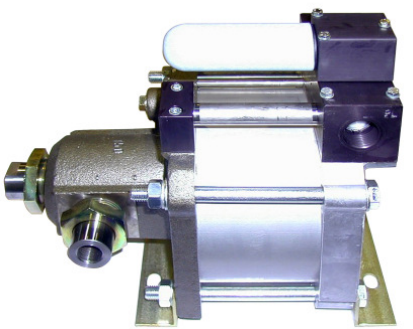
Designation	Figure	Area of application
MSF pump		<p>Pumps for chemical and offshore industries up to 1450 bars. Models: With intermediate chamber, leakage boring and PTFE seals.</p> <ul style="list-style-type: none"> <input type="checkbox"/> Injection of protective agents into pipe systems <input type="checkbox"/> Injection of coolants
GSF high-output pump		<ul style="list-style-type: none"> <input type="checkbox"/> Testing in the aircraft and automotive industries <input type="checkbox"/> Exchange of chemical liquids and pressurization.
GX high-output pump		
GO high-output pump		



3.3 Models

Characteristics	Model
L	Air recuperation ⇒ Intake stroke
01	Spring recuperation ⇒ Only possible with pump model M22 – M189
D	Double-acting ⇒ Higher output capacity, lower pulsation
-2	Two air pistons ⇒ Higher pressure ratio (2* standard)
-3	Three air pistons ⇒ Higher pressure ratio (3* standard)
S	Side-mounted intake nozzles
VE	Special seal for operation with water.
DIR	Direct pilot-valve air ⇒ At low drive pressures
436	Code number for special models (customer-specific)

3.4 Type Designation Code



NOTE

Type designation codes are required for ordering high-pressure pumps.

The type designation code for individual high-pressure pumps is comprised as follows:

1. Design
2. Pressure ratio
3. Model

Example:		
1	2	3
A	37	LVE



NOTE

Explanation of the example:

- M Mini-pump
- 37 Pressure ratio
- L Air recuperation
- VE Special seal for operation with water

4 Assembly and Putting into Service

4.1 General Assembly Information

The pump can be installed in any position you require.

A vertical position provides certain advantages for the durability of the seals, as the mass of the pistons does not then need to be absorbed by the seals.

Fixing angles are provided to anchor the pump.

If the pump is attached to intake and pressure nozzles, you must ensure that the ports used can withstand the pulsating stresses caused by the pump.

It is important that no foreign matter (e.g. drilling dust during wall mounting) should enter into the pump ports during assembly.

Do not remove the blind plugs from the pump ports until immediately before you attach the corresponding ports.

The standard operating temperatures for high-pressure pumps are between -20 °C und $+80\text{ °C}$. Pumps with seal version -VE for water operation can only be used up to $+60\text{ °C}$. For short operating times, temperatures up to $+80\text{ °C}$ are possible. For open-air use at temperatures of 0 °C and below, specially designed pumps must be deployed.

4.2 Compressed Air System

The compressed air port requires a Maximator compressed air control unit to be fitted downstream of the pump.

This air control unit consists of a pressure filter, water separator, shut-off valve, pressure controller, manometer and, where applicable, a safety valve.

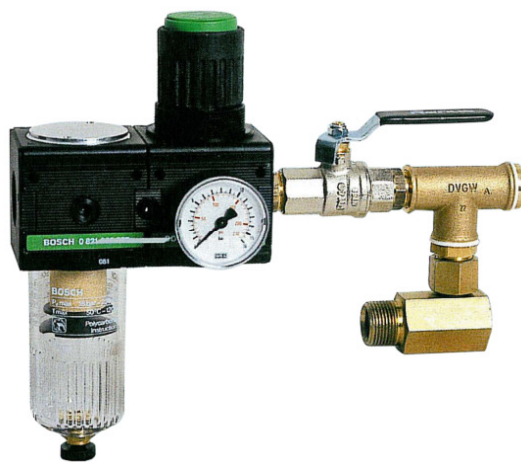

Fig. 3: Compressed air control unit



Assembly and Putting into Service

If the owner of the pumps does not fit a compressed air control unit, the compressed air quality must be ensured in accordance with the manufacturer's requirements.

Requirements on compressed air quality:

- Solid matter
Maximum particle size 5 μm
Maximum particle concentration 5 mg/m^3
- Dew point
Up to +10 °C, water content of 9.4 g/m^3
Up to + 2 °C, water content of 5.6 g/m^3

4.2.1 Compressed air lubricator

A compressed air lubricator is not absolutely essential. All moving pump parts are treated with special grease during assembly.

If the pump is operated with extremely dry air over an extended period, the grease may resinify. We recommend use of a compressed air lubricator in such cases.



CAUTION

Once a compressed air lubricator has been used, the pump must never be operated without it. The oil of the compressed air lubricator washes the grease from the pump, such that permanent lubrication cannot be ensured.

Special grease made by the manufacturer can be used for re-lubrication. If a compressed air lubricator is used, the oil content of the compressed air should be between 1 mg/m^3 and 5 mg/m^3 .

4.2.2 Pipe cross-sections

The compressed air port must not have a smaller specification than the port thread. Reduction to smaller port threads may cause performance losses and pump malfunctions. Excessively long supply pipes may give rise to problems due to pressure drop in small pipes.

4.2.3 Direct pilot-valve air

Pilot-valve air must be connected upstream of a pressure controller for pumps using direct pilot air. The pump is better able to redirect the flow at small drive pressures. If the direct pilot-valve air is not connected, the pump will not function.



NOTE

Direct pilot-valve air is available as a special option for M and S pumps. Double-acting S pumps and G pumps have direct pilot-valve air as standard. The port is marked by "X".

4.3 Hydraulics System

The hydraulic pipes and accessories must be matched to the pump in terms of pressure and cross-section. If this is not the case, the performance capacity and safety of the pump may be impaired.

4.3.1 Intake pipe

To achieve optimum pump performance, the intake pipe needs to be vacuum-tight. Cutting-ring bolted unions are unsuitable.

The intake pipe must not have a larger or smaller specification than the pump's intake port.

Pump type	Maximum intake height (in m)
M4 - M12, S15 - S35, G10 - G35	2.0 m
M22 - M72, S60 - S150, G60 - G150	1.0 m
M111 - M189, G250 - G500	0.5 m

Primary pressure in the intake pipe does not cause any problems. Higher intake levels can be achieved. Smaller intake pipe cross-sections are possible. To prevent damage to both the intake and pressure valves and the HP seal, a filter with a mesh width below 100 µm must be fitted to the intake pipe.



4.3.2 Pressure pipe

The pressure pipe and corresponding accessories must withstand the pump's maximum outlet pressure. Only if a corresponding safety valve has been fitted to the pressure pipe, is it permissible to fall below compressive strength. The cross-section of the pressure pipe must not be smaller than that of the pressure port. A smaller cross-section will cause a reduction in output capacity and increased warming of the pumping medium.

4.3.3 Pumping medium

The pumps must be used exclusively for media contained in the media resistance list. Other media must be tested by MAXIMATOR, prior to use, in respect of their compatibility with the pump materials.

We recommend use of hydraulic oils with a viscosity of 46 - 68 cst in accordance with DIN 51524 T2, DIN 51519 and ISO VG 46. The viscosity of the hydraulic oil should not, however, exceed 100 cst.

Recommended hydraulic oils:

Manufacturer	Hydraulic oil in accordance with DIN 51524 T2, DIN 51519 and ISO VG 46
ARAL	VITAM GF 46
BP	ENERGOL HLP 46
ESSO	NUTO H 46
SHELL	TELLUS Oil 46 HYDROL DO 46 HYDROL HV 46
DEA	ASTRON HLP 46

4.4 Putting into Service

To ensure perfect operation, the pump and the hydraulics system must be ventilated. The pump is operated with a low stroke frequency. A low stroke frequency is achieved by reducing the drive pressure or limiting the volumetric flow. The pumps will not intake medium against an existing operating pressure on the outlet nozzle. The high-pressure side can be ventilated by loosening the pressure pipe. That facilitates the pump's intake. After the pump has been stored for an extended period of time, the o-rings on the control slide valve may stick to the sleeve. The minimum drive pressure increases. A higher drive pressure (about 1.5 to 2 bars) needs to be applied to the pump to enable it to operate.

5 Servicing and Maintenance

5.1 Maintenance Information

The air drives of all pumps are pre-treated with high-performance grease during assembly and require no other type of lubrication. During service and maintenance work on the pumps, control slide valves and air pistons must be treated with an acid- and silicone-free high-performance grease provided by the manufacturer.

5.2 Maintenance

5.2.1 Pressure System

Possible fault	Cause of fault	Fault removal
Pump fails to work at low air pressure.	Friction of o-rings on control slide valve is too high.	<input type="checkbox"/> Re-lubricate. <input type="checkbox"/> Replace o-rings on control slide valve.
	O-rings swell due to use of wrong oil or lubricant.	<input type="checkbox"/> Change o-rings. <input type="checkbox"/> Use acid- and silicone-free lubricant.
Pump only operates at high air pressure.	Air escapes through plunger guide in top cap.	<input type="checkbox"/> Replace o-rings on extension of the plunger.
	Air escapes through filter disc in bottom cap.	<input type="checkbox"/> Replace o-rings on air piston.
Pump does not operate or operates only slowly.	Exhaust or control slide valve covered with ice.	<input type="checkbox"/> Use water separator to de-water compressed air.
	Formation of residue in the silencer.	<input type="checkbox"/> Clean the silencer. <input type="checkbox"/> Replace, where applicable.
Pump does not operate. Air escapes through the exhaust.	O-rings on the control slide valve are defective.	<input type="checkbox"/> Change and grease o-rings.
	O-ring on air piston is defective or worn out.	<input type="checkbox"/> Change and grease o-ring.
Pump does not operate. Air escapes through plunger guide in top cap.	Pilot valve hangs up.	<input type="checkbox"/> Check pilot valve.
		<input type="checkbox"/> Change pilot valve and seal, where applicable.



Servicing and Maintenance

Possible fault	Cause of fault	Fault removal
Pump does not operate. Air flows through small boring on control slide valve housing.	Control slide valve hangs up..	<input type="checkbox"/> Clean control slide valve and sleeve <input type="checkbox"/> Check and, if necessary, replace o-rings and sleeve. <input type="checkbox"/> Lubricate.
Pump does not operate. Air escapes through small boring in bottom cap.	Pilot valve in top or bottom cap hangs up.	<input type="checkbox"/> Clean and grease pilot valve. <input type="checkbox"/> Check for abrasion and replace, if required.
Pump operates with high frequency and short strokes.	Pilot valve in top or bottom cap is defective.	<input type="checkbox"/> Clear and grease pilot valve and, if required, replace it.
	O-ring on plunger piston in top cap is defective.	<input type="checkbox"/> Replace and grease o-ring.

5.2.2 Hydraulics System

Possible fault	Cause of fault	Fault removal
Pump operates without conveying or operates in irregular fashion. It does not achieve the calculated final pressure.	Air in the hydraulics system	<input type="checkbox"/> Ventilate hydraulics system. <input type="checkbox"/> Check intake pipes and bolted unions for leakage. <input type="checkbox"/> Check seal kit between air and hydraulics system.
	Intake pipe too long.	<input type="checkbox"/> Shorten intake pipe.
	Intake cross-section too small.	<input type="checkbox"/> Extend intake cross-section, as otherwise the intake flow will discontinue.
	Failure of the non-return valves.	<input type="checkbox"/> Check, clean and, if necessary, replace non-return valves.
	Intake filter soiled.	<input type="checkbox"/> Clean intake filter.
	Worn packing ring or HP seal.	<input type="checkbox"/> Replace seal kits.

Possible fault	Cause of fault	Fault removal
Liquid escapes through the exhaust.	Worn packing ring or HP seal.	<input type="checkbox"/> Replace seal kits. <input type="checkbox"/> In the event of increased abrasion, inspect the liquid for soiling and seal compatibility.
Liquid escapes through filter disc in the lower cap.	Worn packing ring or HP seal.	<input type="checkbox"/> Replace seal kits.

5.3 Repair



NOTE

Instructions on repairing the high-pressure pumps can be found on the Internet at www.MAXIMATOR.de.



CAUTION

Repair work must be carried out by qualified specialist personnel. Ensure absolute cleanliness. Even the smallest impurities may cause serious damage to precision-machined hydraulic and pneumatic components.

Individual pump parts can be ordered as spare parts from MAXIMATOR. Seals are subject to high abrasion. The order number and composition of the seal kits are specified on the corresponding drawing. The drawing is part of the pump documentation and is enclosed with the packaging of the pump. Please quote the serial number of the pump when ordering spare parts. The serial number (6-digit number) is located on the nameplate and on the housing of the pump.



NOTE

You can ship defective pumps for repair to MAXIMATOR. The repair work is carried out by qualified staff in clean rooms.



5.3.1 Warranty

The manufacturer provides a warranty of 12 months on material quality and workmanship for high-pressure pumps. The warranty shall commence on the date on which the pump is shipped.

The warranty shall not cover defects caused by incorrect handling or malfunctions caused by the use of impermissible liquids and foreign matter in the drive or pumping medium. This shall also apply if the maximum operating pressure is exceeded. Wear parts like seals and guiding elements etc. shall also be excluded from the warranty.

6 Technical Data

Type	Pressure ratio	Stroke volume cm ³	Operating pressure bar	Output capacity l/min	Ports		Weight kg
					Inlet A	Outlet B	
Single-acting MO pumps with one air drive piston							
MO4	1:4	30.5	40	14.81	G 3/4	G 1/2	2.5
MO8	1:9	14.7	90	7.07	G 3/4	G 1/2	2.5
MO12	1:14	9.4	140	4.55	G 3/4	G 1/2	2.5
MO22	1:29	4.6	290	2.22	G 3/8	G 1/4	3.0
MO37	1:47	2.8	470	1.36	G 3/8	G 1/4	3.0
MO72	1:88	1.5	880	0.72	G 3/8	G 1/4	3.0
MO111	1:133	1.0	1000	0.48	G 3/8	G 1/4	3.0
MO189	1:225	0.6	1000	0.28	G 3/8	G 1/4	3.0
Double-acting MO pumps with one air drive piston							
MO22D	1:28	9.2	280	3.91	G 3/8	G 1/4	4.5
MO37D	1:46	5.6	460	2.35	G 3/8	G 1/4	4.5
MO72D	1:86	3.0	860	1.24	G 3/8	G 1/4	4.5
MO111D	1:130	2.0	1000	0.82	G 3/8	G 1/4	4.5
MO189D	1:220	1.2	1000	0.49	G 3/8	G 1/4	4.5
Single-acting S pumps with one air drive piston							
S15	1:17	28.3	170	9.38	G 3/4	G 3/4	9.1
S25	1:25	19.6	250	6.72	G 3/4	G 3/4	9.1
S35	1:39	12.6	390	4.31	G 3/4	G 3/4	9.1
S60	1:61	8.0	610	2.75	G 1/2	G 3/8	9.1
S100	1:108	4.5	1000	1.55	G 1/2	G 3/8	9.1
S150	1:156	3.1	1000	1.08	G 1/2	G 3/8	9.1
Double-acting S-D pumps with one air drive piston							
S15D	1:16	57	160	17.56	G 3/4	G 3/4	14.5
S25D	1:24	39	240	12.00	G 3/4	G 3/4	14.5
S35D	1:38	25.2	380	7.58	G 3/4	G 3/4	14.5
S60D	1:60	16.0	600	4.80	G 1/2	G 3/8	14.5
S100D	1:107	9.0	1000	2.68	G 1/2	G 3/8	14.5
S150D	1:155	6.2	1000	1.85	G 1/2	G 3/8	14.5



Technical Data

Type	Pressure ratio	Stroke volume cm ³	Operating pressure bar	Output capacity l/min	Ports		Weight kg
					Inlet A	Outlet B	
Single-acting M pumps with one air drive piston							
M4	1:4	30.5	40	14.81	G 1	G 1/2	3.0
M8	1:9	14.7	90	7.07	G 3/4	G 1/2	3.0
M12	1:14	9.4	140	4.55	G 3/4	G 1/2	3.0
M22	1:28	4.6	280	2.22	G 3/8	G 3/8	2.8
M37	1:46	2.8	460	1.36	G 3/8	G 3/8	2.8
M72	1:86	1.5	860	0.72	G 3/8	G 3/8	2.8
M111*	1:130	1.0	1300	0.48	G 3/8	G 3/8	2.8
M189*	1:220	0.6	2200	0.28	G 3/8	G 3/8	2.8
Double-acting M-D pumps with one air drive piston							
M22D	1:28	9.2	280	3.91	G 3/8	G 3/8	3.7
M37D	1:46	5.6	460	2.35	G 3/8	G 3/8	3.7
M72D	1:86	3.0	860	1.24	G 3/8	G 3/8	3.7
M111D*	1:130	2.0	1300	0.82	G 3/8	G 3/8	3.7
M189D*	1:220	1.2	2200	0.49	G 3/8	G 3/8	3.7
Single-acting M-2 pumps with two air drive pistons							
M111-2*	1:261	1.0	2500	0.35	G 1/4	9/16-18 UNF	3.9
M189-2+	1:440	0.6	4000	0.21	G 1/4	9/16-18 UNF	3.9
Single-acting M-3 pumps with three air drive pistons							
M111-3*	1:391	1.0	2500	0.24	G 1/4	9/16-18 UNF	4.6
M189-3*	1:660	0.6	4000	0.14	G 1/4	9/16-18 UNF	4.6
Single-acting G pumps with one air drive piston							
G10	1:11	90	110	18.53	G 1	G 3/4	16.0
G15	1:16	62.0	160	12.86	G 1	G 3/4	16.0
G25	1:28	35.3	280	7.24	G 3/4	G 3/4	14.5
G35	1:40	24.5	400	5.02	G 3/4	G 3/4	14.5
G60	1:63	15.4	630	3.21	G 3/4	G 1/2	13.5
G100*	1:113	8.8	1050	1.81	G 3/4	G 1/2	13.5
G150*	1:151	6.6	1450	1.36	G 3/4	G 1/2	13.5



Type	Pressure ratio	Stroke volume cm ³	Operating pressure bar	Output capacity l/min	Ports		Weight kg
G250*	1:265	3.8	2650	0.77	G 1/2	9/16-18 UNF	13.5
G300*	1:314	3.2	3140	0.65	G 1/2	9/16-18 UNF	13.5
G400*	1:398	2.5	4000	0.51	G 1/2	9/16-18 UNF	13.5
G500S+	1:519	1.9	4500	0.39	G 1/2	9/16-18 UNF	13.5
Double-acting G pumps with one air drive piston							
G10D	1:10	180.0	100	28.85	G 1	G 3/4	22.0
G15D	1:15	124.0	150	19.84	G 1	G 3/4	22.0
G25D	1:27	70.6	270	11.36	G 3/4	G 3/4	19.0
G35D	1:40	29.0	400	7.74	G 3/4	G 3/4	19.0
G60DS	1:63	31.4	630	5.04	G 3/4	G 1/2	17.0
G100DS*	1:113	17.6	1050	2.78	G 3/4	G 1/2	17.0
G150DS*	1:151	7.6	1450	2.10	G 3/4	G 1/2	17.0
Single-acting G pumps with two air drive pistons							
G10-2	1:22	90.0	220	15.89	G 1	G 3/4	20.5
G15-2	1:32	62.0	330	11.02	G 1	G 3/4	20.5
G25-2	1:56	35.3	560	6.19	G 3/4	G 3/4	19.5
G35-2	1:80	24.5	800	4.30	G 3/4	G 3/4	19.5
G60-2*	1:126	15.4	1260	2.76	G 3/4	G 1/2	18.0
G100-2*	1:226	8.8	2100	1.55	G 1/2	9/16-18 UNF	18.0
G150-2*	1:300	6.6	2900	1.16	G 1/2	9/16-18 UNF	18.0
G250-2*	1:530	3.8	4500	0.66	G 1/4	9/16-18 UNF	22.0
G300-2*	1:628	3.2	4500	0.56	G 1/4	9/16-18 UNF	22.0
G400-2*	1:796	2.5	5500	0.44	G 1/4	9/16-18 UNF	22.0
G500-2*	1:1038	1.4	5500	0.34	G 1/4	9/16-18 UNF	22.0



Technical Data

Type	Pressure ratio	Stroke volume cm ³	Operating pressure bar	Output capacity l/min	Ports		Weight kg
Single-acting MSF pumps with one air drive piston, intermediate chamber and leakage boring							
MSF4	1:4	30.5	40	14.81	G 1	G1/2	6.7
MSF8	1:9	14.7	90	7.07	G 3/4	G1/2	6.7
MSF12	1:14	9.4	140	4.55	G 3/4	G1/2	6.7
MSF22	1:28	4.6	280	2.22	G 3/8	G 3/8	3.5
MSF37	1:46	2.8	460	1.36	G 3/8	G 3/8	3.5
MSF72	1:86	1.5	860	0.48	G 3/8	G 3/8	3.5
MSF111	1:130	1.0	1000	0.28	G 3/8	G 3/8	3.5
Single-acting GSF pumps with one air drive piston, intermediate chamber and leakage boring							
GSF10	1:11	90.0	110	18.53	G 1	G 3/3	20.0
GSF15	1:16	62.0	160	12.86	G 1	G 3/4	20.0
GSF25	1:28	35.3	280	7.24	G 3/4	G 3/4	19.0
GSF35	1:40	24.5	400	5.02	G 3/4	G 3/4	19.0
GSF60	1:63	15.7	630	3.21	G 3/4	G 1/2	18.0
GSF100*	1:113	8.8	1050	1.81	G 3/4	G 1/2	18.0
GSF150*	1:151	6.6	1450	1.36	G 3/4	G 1/2	18.0

Type	Pressure ratio	Stroke volume cm ³	Operating pressure bar	Output capacity l/min	Ports		Air drive	Weight kg
GX pumps								
GX35	1:36	180	360	24.50	1 FNPT	3/8 FNPT	G 3/4	24.0
GX60	1:66	65	600	23.00	1 FNPT	3/8 FNPT	G 3/4	24.0
GX100	1:117	36	1000	9.00	1 FNPT	3/8 FNPT	G 3/4	24.0

Pumps marked with * have a port with G (BSP) thread up to max. 1000 bars as standard. Port threads for higher pressures with 9/16-18UNF can be supplied.