



High Pressure Technologies, LLC.

HPT

26364 Ruether Ave
Santa Clarita, CA 91350 U.S.A.
Tel: (661)-251-5069
Fax: (661)-251-6745
<http://www.highpressuretech.com>

8900 & 9000 SERIES

Up To 250 PSI



Ask your HPT representative for the HPT Filter Interchange Guide with over 100,000 interchangeable elements available.

HOW TO ORDER

EXAMPLE FILTER ASSEMBLY

89	A	1	-	0	0	-10CL	V
	A	B	C	D	E	F	

EXAMPLE REPLACEMENT ELEMENT

89	E	10CL	V
	A	E	F

EXAMPLE HEAD ONLY

89	H	1	-	0	0
	A	B	C	D	

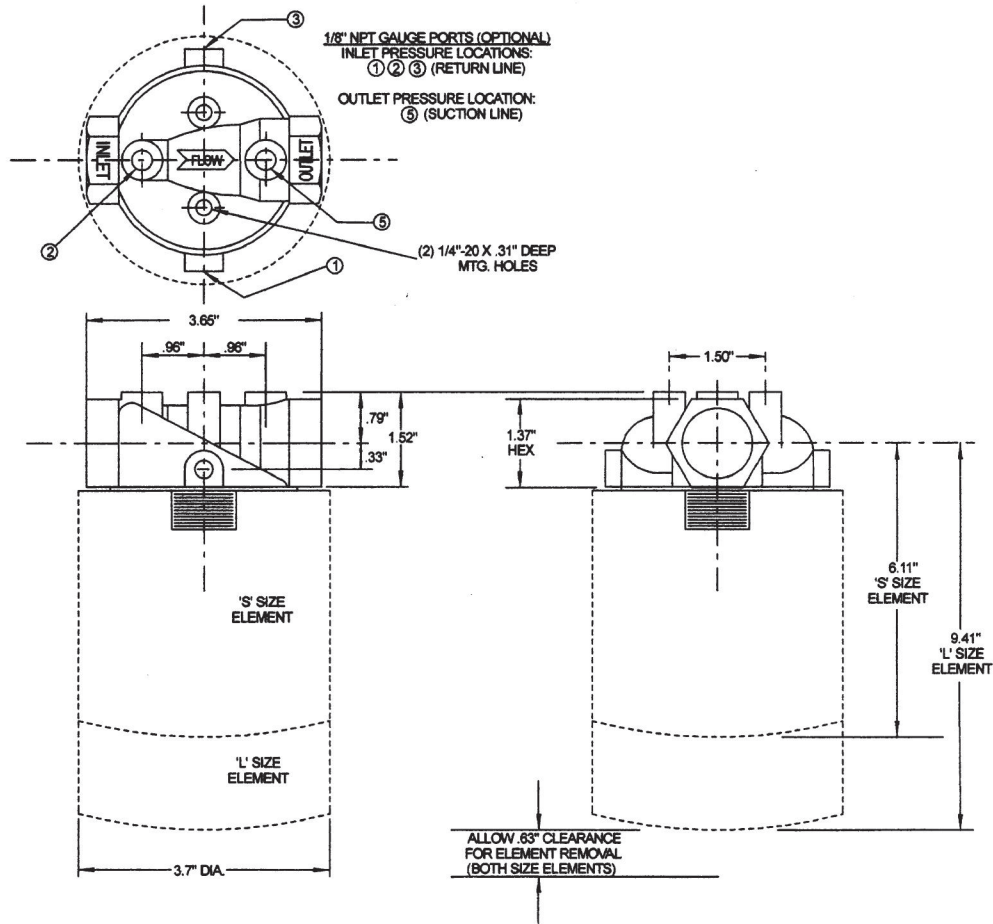

A

CODE	DESCRIPTION
A	Filter Assembly
E	Element Only
H	Head Only

B

CODE	PORT SIZE
1	1/2" - NPT
2	3/4" - NPT
3	1" - NPT
4	1/2" - SAE
5	3/4" - SAE
6	1" - SAE

C

CODE	BY-PASS SETTING
0	No-Bypass
1	3-PSI
2	5-PSI
3	15-PSI
4	25-PSI
5	50-PSI

D

CODE	DESCRIPTION
0	No Gage Ports
1	Inlet
2	Inlet
3	Inlet
5	Outlet

E

CODE	ELEMENT DESCRIPTION
3CS	3-Mic. Cellulose
3CL	3-Mic. Cellulose
3MS	3-Mic. Abs. Micro Glass
3ML	3-Mic. Abs. Micro Glass
10CS	10-Mic. Cellulose
10CL	10-Mic. Cellulose
10CWS	10-Mic. Cellulose Water Absorbing
10CWL	10-Mic. Cellulose Water Absorbing
12MS	12-Mic. Abs. Micro Glass
12ML	12-Mic. Abs. Micro Glass
25CS	25-Mic. Cellulose
25CL	25-Mic. Cellulose
25MS	25-Mic. Abs. Micro Glass
25ML	25-Mic. Abs. Micro Glass
141SS	100-Mesh Stainless
141SL	100-Mesh Stainless

F

CODE	SEAL SELECTION
Omit	Nitrile
E	EPR
V	Viton

MATERIALS

(Head) Cast Aluminum
(Element) Drawn Steel

For Standard Element Recommended

Working Pressure:
175 psi

Rated Flow:
Up to 37 GPM

Temperature:
-65° to +250°F. Operating

Applications:
Petroleum based fluids only.
Consult factory
for synthetic fluids.

HOW TO ORDER

EXAMPLE FILTER ASSEMBLY

90 A 1 - 4 25 - 3ML E
A B C D E F

EXAMPLE REPLACEMENT ELEMENT

90 E 3ML E
A E F

EXAMPLE HEAD ONLY

90 H 1 - 4 25
A B C D

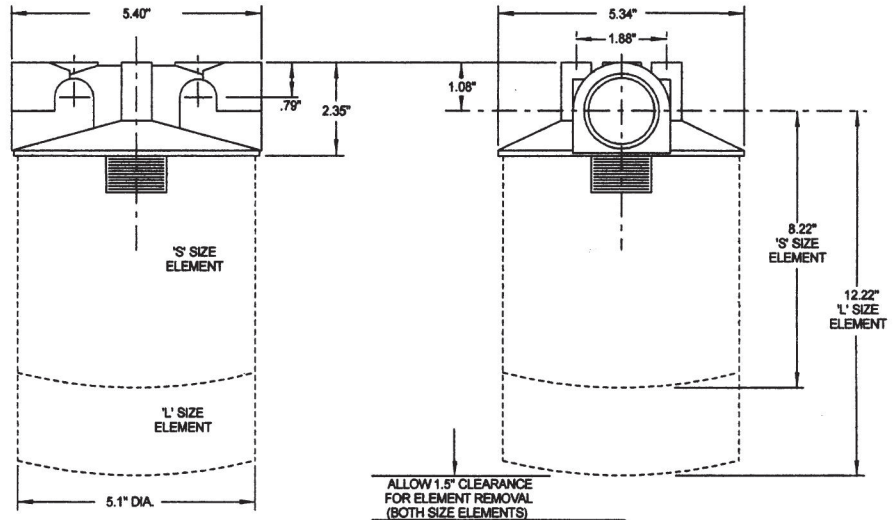
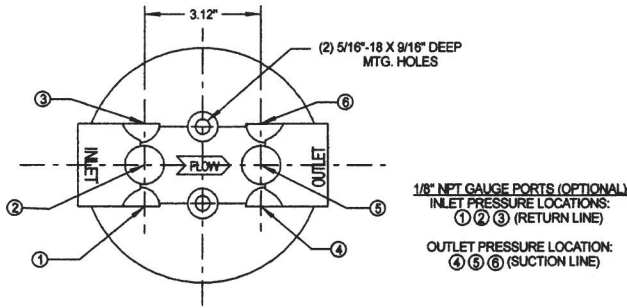

A

CODE	DESCRIPTION
A	Filter Assembly
E	Element Only
G	316 Head Only
H	Head Only

B

CODE	PORT SIZE
1	1" - NPT
2	1-1/4" - NPT
3	1-1/2" - NPT
4	1" - SAE
5	1-1/4" - SAE
6	1-1/2" - SAE

C

CODE	BY-PASS SETTING
0	No-Bypass
1	3-PSI
2	5-PSI
3	15-PSI
4	25-PSI
5	50-PSI

D

CODE	DESCRIPTION
0	No Gage Ports
1	Inlet
2	Inlet
3	Inlet
4	Outlet
5	Outlet
6	Outlet

E

CODE	ELEMENT DESCRIPTION
1MS	1-Mic. Abs. Micro Glass
1ML	1-Mic. Abs. Micro Glass
3CS	3-Mic. Cellulose
3CL	3-Mic. Cellulose
3MS	3-Mic. Abs. Micro Glass
3ML	3-Mic. Abs. Micro Glass
6MS	6-Mic. Abs. Micro Glass
6ML	6-Mic. Abs. Micro Glass
10CS	10-Mic. Cellulose
10CL	10-Mic. Cellulose
10CWS	10-Mic. Cellulose Water Absorbing
10CWL	10-Mic. Cellulose Water Absorbing
12MS	12-Mic. Abs. Micro Glass
12ML	12-Mic. Abs. Micro Glass
25CS	25-Mic. Cellulose
25CL	25-Mic. Cellulose
25MS	25-Mic. Abs. Micro Glass
25ML	25-Mic. Abs. Micro Glass
141SS	100-Mesh Stainless
141SL	100-Mesh Stainless

F

CODE	SEAL SELECTION
Omit	Nitrile
E	EPR
V	Viton

MATERIALS

(Head) Cast Aluminum
(Element) Drawn Steel

For Standard Element

Recommended Working Pressure:

100 psi

Rated Flow:

Up to 70 GPM (return)
25 GPM (suction)

Temperature:

-65° to +250°F. Operating

Applications:

Petroleum based fluids only.
Consult factory for synthetic fluids.

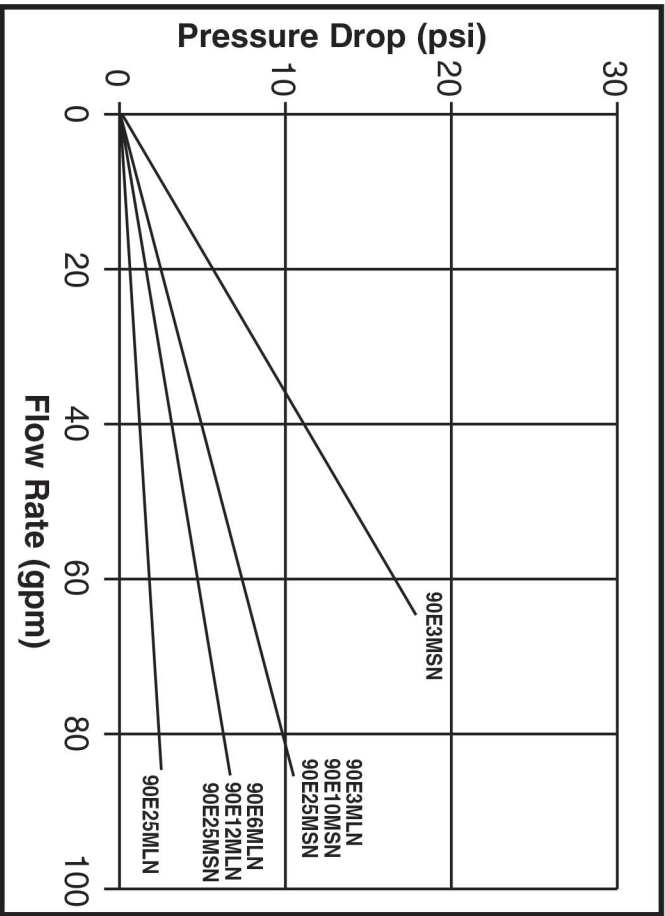
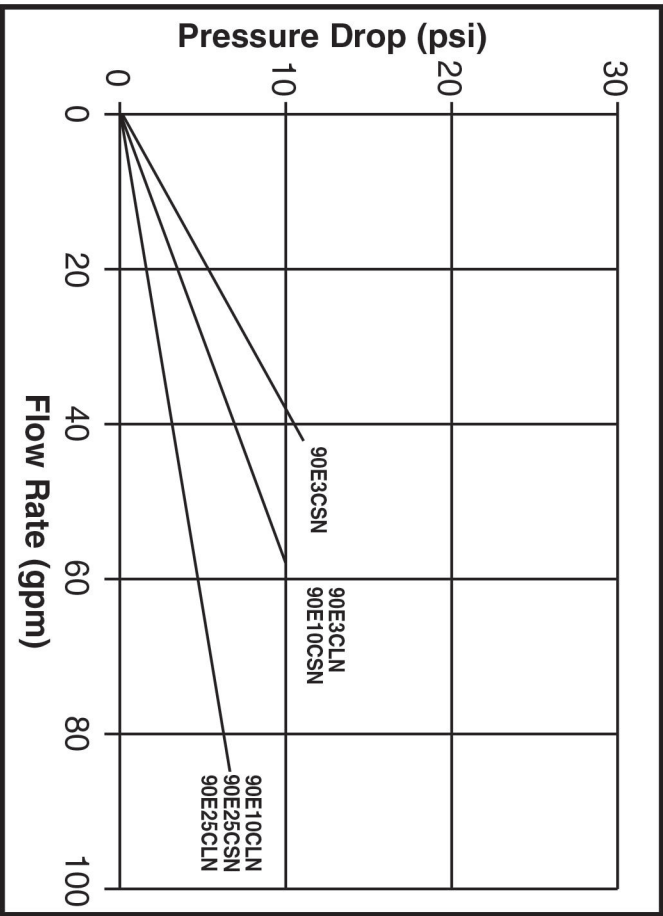
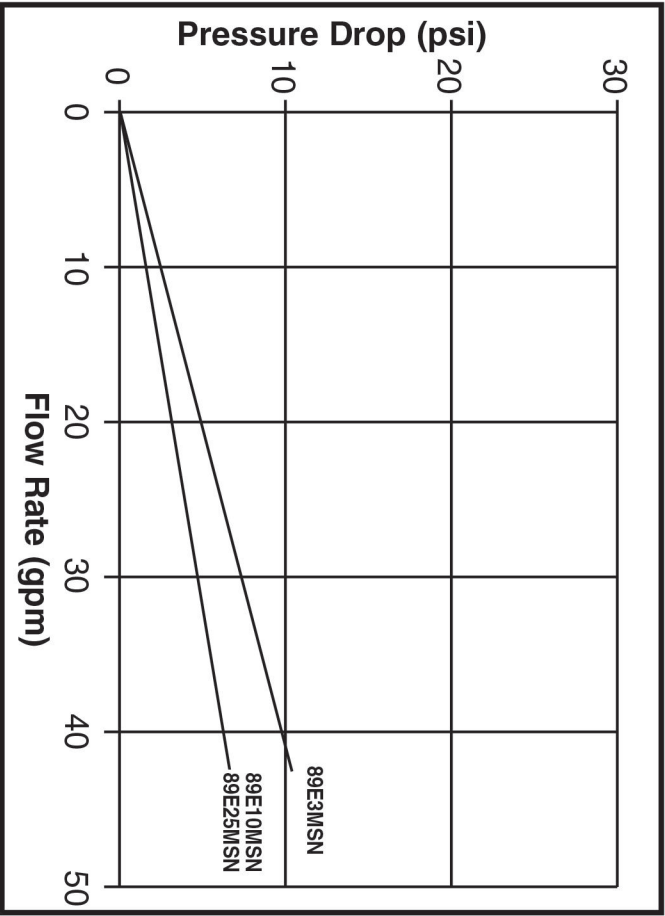
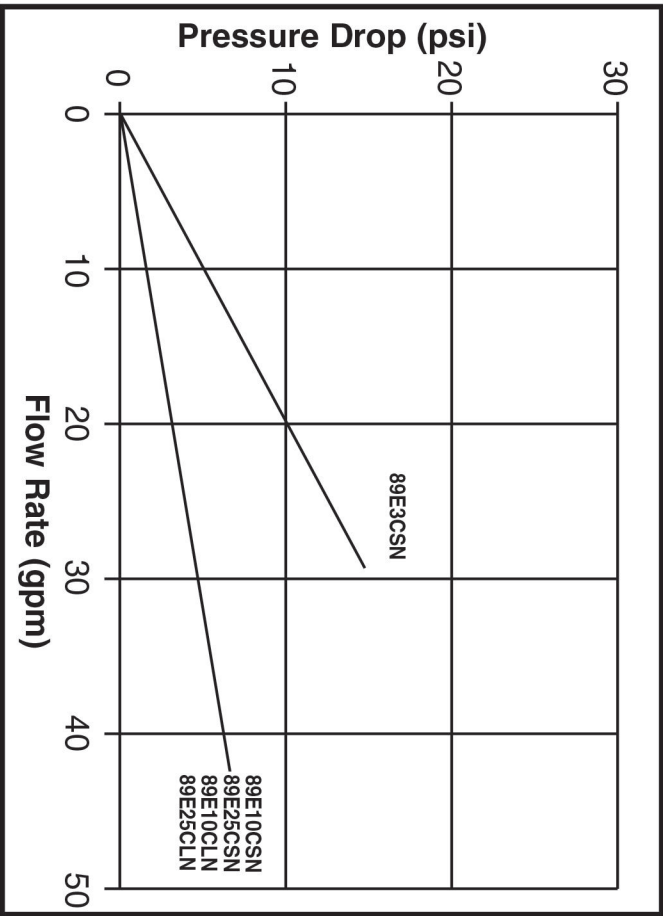

150 SUS (32 cSt)
Specific Gravity (0.9)